

SATLOC
FALCON

SATLOC
FALCON
PRO



USER MANUAL

WHAT'S INSIDE!

- Chapter One: Overview
- Chapter Two: General Setup
- Chapter Three: Basic Tasks
- Chapter Four: Advanced Setup

This device complies with part 15 of the FCC Rules. Operation is subject to the following two conditions:

1. This device may not cause harmful interference, and
2. this device must accept any interference received, including interference that may cause undesired operation.

Copyright Notice

Satloc, a company of Texas Transland, LLC



Copyright Satloc © (2022). All rights reserved.

No part of this manual may be reproduced, transmitted, transcribed, stored in a retrieval system or translated into any language or computer language, in any form or by any means, electronic, mechanical, magnetic, optical, chemical, manual or otherwise, without the prior written permission of Satloc.

Read and Follow Safety Messages



Satloc GPS systems are intended for VFR (visual flight rules) use only. Information provided is intended solely for recording aerial application activities and enhancing application guidance. Satloc is not a replacement for best pilot practices. Follow required procedures, flight rules, and regulations during use.

- In these instructions, you may see the heading  and/or the safety alert symbol . They indicate a hazardous situation that, if not avoided, could result in death or serious injury. The safety messages provide information to identify a hazard associated with potential injury.
- Read and understand this manual and all the warnings below before installing, operating, or performing maintenance or service. FAILURE TO DO SO MAY CAUSE IRREVERSIBLE DAMAGE TO YOUR SYSTEM.
- Keep this manual and all related safety information with the manuals for your aircraft.

Latest Version of the Falcon Installation Guide

Satloc is dedicated to providing updated versions of installation guidebooks for its customers. For the latest version of the Falcon User Manual, visit www.Satloc.com.

Notice to Customers

Contact your local dealer for technical assistance. To find an authorized dealer near you, visit www.Satloc.com.

Transland

1206 Hatton Rd.
Wichita Falls, TX 76302
Phone: 940-687-1100
Fax: 940-687-1941
www.TranslandLLC.com

Documentation Feedback

Satloc, a division of Transland, is committed to the quality and continuous improvement of our products and services. We encourage and appreciate any feedback regarding this guide and any of our products by writing to the following email address: Sales@Translandllc.com.

WARNINGS, CAUTIONS & NOTES



Warning: Satloc GPS systems are intended for VFR (visual flight rules) use only. Information provided is intended solely for recording aerial application activities and enhancing application guidance. Satloc is not a replacement for best pilot practices. Follow required procedures, flight rules, and regulations during use.



Warning: The altitude calculated by GPS receivers is a geometric height above Mean Sea Level and could vary significantly from the altitude displayed by pressure altimeters. Always use the pressure altitude displayed by the aircraft altimeter when determining or selecting aircraft altitude.



Warning: To reduce the risk of unsafe operation, carefully review and understand all aspects of the Falcon's User Guide and the Pilot's Operating Handbook of the aircraft. Thoroughly practice basic functions before actual use. During flight operations, carefully compare indications from the Falcon to all available navigation sources, including the information for other NAVAIDS, visual sightings, charts, etc. For safety purposes, always resolve any discrepancies before continuing navigation.



Warning: For safety reasons, Falcon operational procedures must be learned on the ground.



Warning: The United States government operates the Global Positioning System and is solely responsible for its accuracy and maintenance. The GPS system is subject to changes that could affect the accuracy and performance of all GPS equipment.



Warning: Do not use background maps for primary navigation. Basemap data is intended only to supplement other approved navigation data sources and should be considered as an aid to enhance situational awareness.



Caution: Avoid using any chemical or abrasive cleaners on the touchscreen and/or plastic casing. Clean the touchscreen with a soft, clean, lint-free cloth. Use water, isopropyl alcohol, or eyeglass cleaner if needed.



Caution: The Falcon GPS does not contain any user-serviceable parts. Repairs should only be made by an authorized Satloc Dealer. Unauthorized repairs or modifications could void the warranty and the pilot's authority to operate this device under FAA/FCC regulations.



Note: All visual depictions in this document, including screen images of the GPS panel and displays, are subject to change and may not reflect the most current GPS system and aviation databases. Depictions of equipment may differ slightly from the actual equipment.



Note: Interference from GPS repeaters operating inside nearby hangars can cause an intermittent loss of attitude and heading displays while the aircraft is on the ground. Moving the aircraft more than 100 yards away from the source of the interference should alleviate the condition.



Note: Polarized eyewear may cause the flight displays to appear dim or blank.

CHAPTER 1: OVERVIEW

WHAT'S INSIDE!

- 1.1 Overview of Models
- 1.2 A New Way of Doing 'Jobs'
- 1.3 Touchscreen Display Overview
- 1.4 Navigate the Falcon Models
- 1.5 Startup Screen for Falcon Models
- 1.6 Moving Map Screen Overview
- 1.7 Main Menu Overview
- 1.8 Navigating Submenus
- 1.9 System Diagnostics

1.1 OVERVIEW OF MODELS

Satloc offers two versions of the next generation GPS system — Satloc® Falcon™ and Satloc Falcon Pro™. These aerial guidance GPS systems provide precise and flexible guidance technology for today's aerial spray market.

SATLOC® FALCON

SATLOC® FALCON PRO

BASIC MODEL



Satloc Falcon GPS system will meet all your liquid application needs. Features include WiFi connection capability, basic patterns, log files, guidance modes, real-time background maps, Satloc Cloud connection, and optional upgrade unlock codes for enhanced features.

PRO MODEL



Satloc Falcon Pro GPS system is equipped with all the right tools and ready for all liquid and dry jobs! The Falcon Pro includes all the basics and more. The additional features are enhanced patterns, enhanced guidance modes, top hat control, hopper fill meter, boom control, all the unlocks, auto dispersal, PMAPs, and dry controller.

Technical Specifications

Wireless Data Communications: WiFi, 802.11 AC, 2.4 GHz or 5 GHz	Memory (RAM): 4 GB @ DDR4 SO DIMM	Mount Style: Horizontal or Rack
Main CPU: Intel Core i5-8365UE, 8th generation @ 1.60 GHz with Turbo up to 4.1 GHz	Power Input: 12-30 VDC, reverse input, fault output and surge protection	Footprint: Rack Mount - 6" x 3.9" (23.3 sq in) Horizontal Mount - 6" x 6" (36 sq in)
Solid State Drive: 256 GB for Falcon (M.2 NVMe PCIe Gen3) 512 GB for Falcon Pro (M.2 NVMe PCIe Gen3)	Screen: 7" or 9" Touchscreen with multi-function display	20Hz SBAS GPS with optional GLONASS Falcon Pro (Only) -enhanced by 100 Hz inertial measurement

Quick Comparison Chart

Below is a quick comparison of the two models as of July 2023.

SATLOC®

Make a Choice
for the
System that
Best Fits You



System Features	SATLOC FALCON	SATLOC FALCON PRO
CPU with 2 Mounting Options	✓	✓
Multi-Language (English, Spanish, Portuguese)	✓	✓
7" & 9" Screen Options	✓	✓
ADS-B In	✓	✓
Solid State Hard Drive	256 GB	512 GB
Built In WiFi Connection	✓	✓
Satloc Cloud Connection (With 3rd Party Options)	✓	✓
Real Time Background Maps	✓	✓
Offline Background Maps (Additional Charges Apply)	✓	✓
Shape File Support	✓	✓
Cockpit Encoder Knob (Option to Upgrade)	Single	Dual
Ag Laser Connection (Plug & Fly, No Additional Cabling)	✓	✓
Guidance Modes (Enhanced Features in the Falcon Pro)	✓	✓
PMAP's	Unlock Required -\$	✓
Auto Dispersal (Formerly Spray Off)	Unlock Required -\$	✓
Boom Control Input (With Enhanced Patterns)	Unlock Required -\$	✓
Controls & Monitors 4 Valves		✓
Dry Controller / Variable Rate		✓
Transland Meterate		✓
External CAN		✓
Flow Meter Input		✓
Inertial Measurement Unit (IMU)		✓
Top Hat Control Inputs (Additional Hardware Required)		✓
Integrated AIMMS Capability		Optional Upgrade

Satloc Cloud

Both Falcon models are compatible with Satloc Cloud. Satloc Cloud is a Satloc software product that can be used in conjunction with Falcon and Falcon Pro to perform more advanced tasks. Satloc Cloud is a real-time web-based asset tracking tool that enables companies to track the position and position-related data of aircraft and other assets, such as spotter vehicles and loader trucks.



The Satloc Cloud symbol will appear in this user manual when there is a function that requires integration with the Falcon Models and Satloc Cloud.

Visit www.Satloc.com for more information about Satloc Cloud, or contact your local Satloc dealer.

1.2 A NEW WAY OF DOING 'JOBS'

Jobs Are Everything

In the Falcon system, all your data is contained in a Job. This means that all that data is contained in the Job no matter what day you applied, how many patterns you used during an application, or how many times or even days you returned to apply.

Jobs can be created in real-time. Additionally, Jobs can be made from a polygon(s) or prescription maps and then loaded into the Falcon through USB or the Cloud. They all behave the same.

A Job and all the related paint and swathing data are opened on the Falcon by 1) loading the Job (through the menu or a Hotkey) or 2) by returning to a Mark (created while that Job was previously open).

If the user creates a new job on the Falcon, a default job name is suggested with the Falcon's serial number, date of application, and daily job counter as the job name. The user could instead name the Job something meaningful: "Farmer Brown Field."

BENEFITS OF ALL DATA CONTAINED IN JOBS

01

Pilots do not need to remember all the logs that make a whole application together.

02

All paint and swathing data is loaded each time a Job is loaded.

03

All Job data is exported as one log file from the Falcon. Within the Satloc Cloud, all Job data has a common log name for a group export. Any export can then be loaded in MapStar or other programs.

04

The Falcon contains all swathing data (pattern, swath number, A-B Line, etc.) within the Job even when a Mark is not set. So, any swathing can be restored as active to continue.

When to start a new Job?

The answer is based on how much data you want to be grouped.

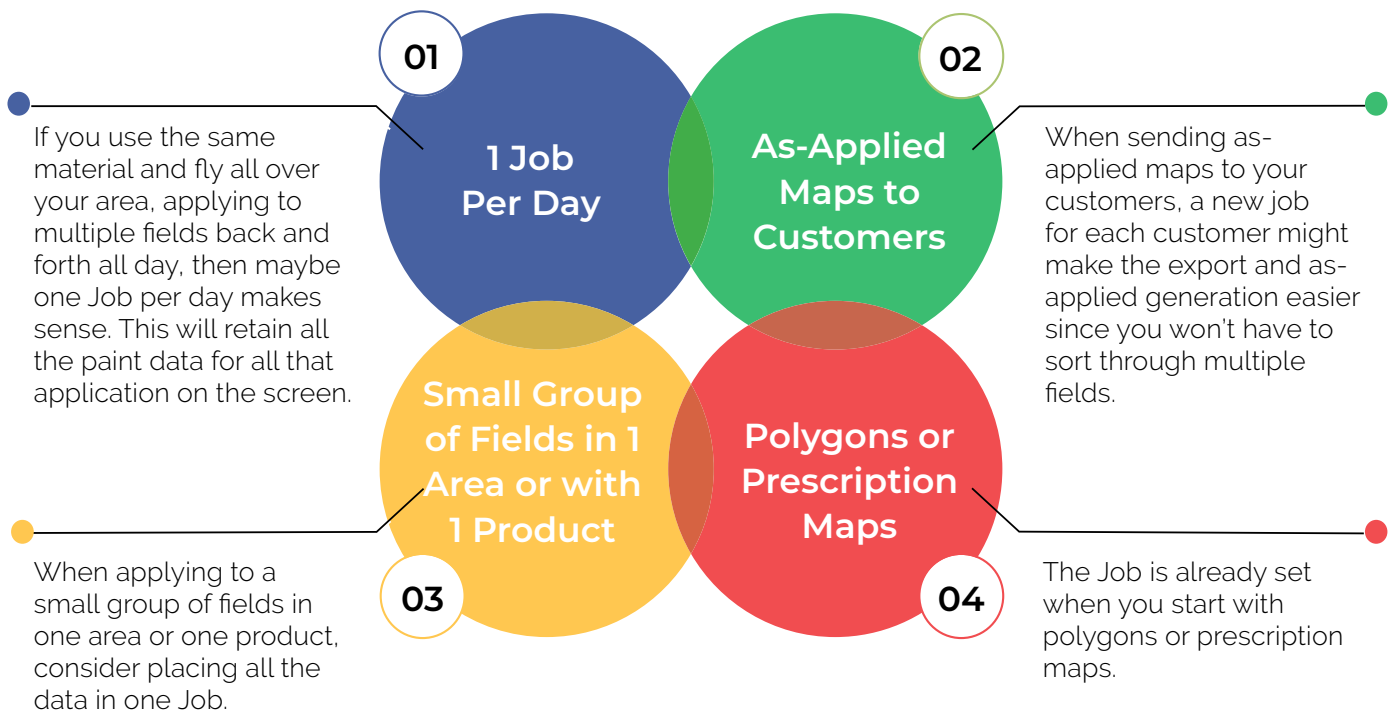

Jobs are also how data is shared between Falcons. When released, this feature will allow two or more Falcons (within the same Cloud company) to open the same Job and apply synchronously, sharing all the paint and swathing data.

1.3 TOUCHSCREEN DISPLAY OVERVIEW

LED Light Indicators

Every Satloc Falcon/Falcon Pro touchscreen display features LED light indicators to give the user information about the current state of the Falcon/Falcon Pro and the systems it communicates with. The LED lights represent power, power distribution, software, CPU / IF3, GPS, ADS-B In, Cloud, and 3rd party connections.

- Red LED indicates – system error
- Green LED indicates - no system error
- Orange LED indicates – system warning

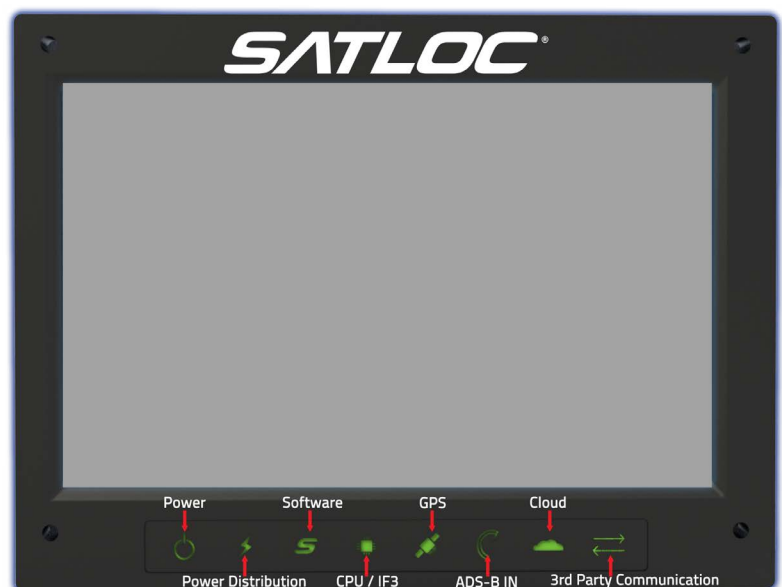

1.4 NAVIGATING THE FALCON MODELS

Using the Touchscreen

Use your finger(s) or a stylus to touch the screen and interact with all Falcon models.

Zooming refers to increasing or decreasing (zooming in or zooming out) the magnification of the screen. Use two fingers on the screen, and move them apart to move in, or together to zoom out.



ZOOM IN



ZOOM OUT

Scrolling refers to moving or shifting the screen in a specific direction (such as up or down) so you can see detail that may not be currently visible.



SWIPE UP



SWIPE DOWN

The Falcon/Falcon Pro software has on/off slider buttons. Single tap to turn the function on or off. If the button is green, the function is ON. When the button is greyed out, the function is OFF.



SINGLE TAP

Using the Encoder Knob

The Falcon model has a single encoder knob that performs the basic functions of dimming, brightening, and zooming. A dual encoder knob comes with the Falco Pro model, which gives pilots more options to customize and use to their preferences. Quick profiles can be created for both encoder knobs to perform a selected function. Examples of the dual encoder knob are application rate, center map, swath width, open menu, open setup, etc. Click [here](#) to view a video on how-to use and customize the encoder knob. Also, how-to use and customize the encoder knob is explained later in this manual.

1.5 STARTUP SCREENS FOR FALCON SYSTEMS

Startup Screens

Every time a Falcon system initially starts, a warning is displayed. Select 'OK' to acknowledge the statement.



Upon launch or when changing flow modes, the Falcon needs direction on how to handle the new data. This startup menu displays for the pilot to have a quick pick of the next step.



- 1 Opens a menu to load an existing job.
- 2 Opens a menu to select a previous mark.
- 3 Returns to Mark Zero. (Mark Zero is the last time you stopped applying.)
- 4 Opens a menu to create a new Job and name it.
- 5 Automatically creates a new Job with a default name based on the serial number, date, and daily job counter.
- 6 Opens a menu to import a Job from a USB.
- 7 Opens up the main menu.

1.6 MOVING MAP SCREEN OVERVIEW

After startup or a Job is loaded or created, the touchscreen displays the moving map screen. The moving map screen is the main display in Falcon/Falcon Pro. Chapter 2 details setting up display areas on the moving map screen.



1 Top Display Area

In the Top Display Area, three fields contain user-selected information. This is editable from the screen display menu and is part of the areas automatically updated when Guidance Modes change. The information presented is as large of a font as possible and is usually visible, regardless of user interaction. This is the best location to put key information needed to be read quickly and easily. Appendix B shows options of what can be shown in the Top Display Area and Left Display Area.

2 Moving Map Area

The moving map area ('moving map') shows a GIS-generated map of the field showing the flight track, swathing lines, application areas "paint," any job polygons, Marks, and other relevant information. Satellite or street-map backgrounds are available when the Falcon is connected to the internet.

A distinct capability of the Falcon/Falcon Pro is the ability to upload offline background maps. Offline background maps are helpful for aircraft with slow or reduced internet capabilities. When there is a poor or limited internet connection, online background maps might not appear, which is why offline background maps are beneficial. They are easy to load and can provide peace of mind. Because of additional costs, additional fees apply for offline background maps.

3 Left Display Area

At the left is a collapsible panel that contains user-selected information and buttons. This is editable from the screen display menu and is part of the areas automatically updated when Guidance Modes change. Selections that are buttons have a blue background and typically allow the user to make quick edits to that information.

4 Hotkeys Area

Hotkeys are quick actions the user can take with a single click. The Falcon has multiple pages of Hotkeys (7 buttons per page). Think of this as pages of apps on a smartphone. The whole set of Hotkeys (all pages) is editable from the Hotkey menu and is part of the areas automatically updated when Guidance Modes change. Satloc recommends setting the most used Hotkeys on the first page and lesser used Hotkeys on subsequent pages. Appendix C shows options of what can be shown in the Hotkeys Area.

5 Bottom Display Area

Various buttons will appear in the Bottom Display Area, depending on the functions used.

 The Setup Button opens a concise page with common information and user settings.

 These buttons zoom in and out. Also, a user can use his/her fingers to zoom in and out by pinching fingers in and out.

 The plane will remain at the center of the map unless the user drags the map to see something off screen. The recenter button will restore the aircraft to the center.

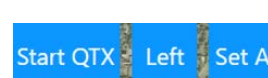
 This area shows multiple buttons with various functions at different times, depending on the Guidance Mode and the current swathing state. For example, what is shown on the Moving Map image on the previous page is different from what is displayed to the left of this paragraph.

6 Information Area

This area display various information, depending upon the mode selected. Dry display information only displays when Falcon Pro is in 'Dry Mode.' When in Liquid mode, auto dispersal will appear. This area is also for warnings and notifications. When a function is in use, its box will turn green. For example, when the arm is activated, the Arm box's light will be green.

7 Menu Buttons

The menu button on the top left-hand side will take a user back to the moving map screen. The menu in the bottom will lead a user to the main menu screen. HOWEVER, if you are on the moving map screen, it will take you to the Main Menu Screen.

8 Expand and Collapse Menus







 When these icons appear, the menu can expand and collapse.



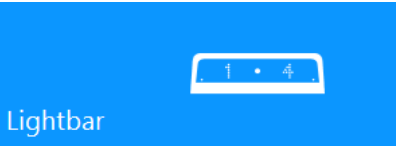

1.7 MAIN MENU OVERVIEW

From the Moving Map screen, touch the 'Menu' button to navigate to the Main Menu.



Menu Name	Menu Button Image	Associated Function
1 Application		The 'Application' button takes the user to settings for the particular application mode selected. This button will lead a user to the following functions. Liquid 2nd Level Menu Dry 2nd Level Menu 1. Flow Control 1. Flow Control 2. Boom Dispersal 2. Gate Dispersal 3. Hopper 3. Hopper
2 Devices		The 'Devices' menu is where the user can initially set up the Falcon system hardware. This menu sets the details of how hardware connects and functions. Additionally, this includes setting how the inputs function for various Guidance Modes. Information in this menu is not often changed once set. This button will lead a user to the following functions. 1. Booms 2. Liquid Advanced 3. Liquid Accesories 4. Liquid Controller 5. Falcon Advanced 6. Aircraft Setup 7. Spreader Setup 8. Input 9. Output
3 Mapping		The Mapping menu sets the Falcon's interaction with the world around it. This button will lead a user to the following functions. 1. Map Setup 2. Guidance Modes 3. Waypoints 4. GPS/IMU Setup 5. ADS-B In Setup

<p>4 Data</p>		<p>The Data button provides the Cloud connection status and tools to export log files to USB. This button will lead a user to the following functions.</p> <ol style="list-style-type: none"> 1. Satloc Cloud 2. External Data 3. Log Export
<p>5 Diagnostics</p>		<p>The Diagnostics menu is one menu to check the status of every system. Also, there is a list of all software and firmware versions in the system and a quick way to check the status of every system input. This button will lead a user to the following diagnostic functions.</p> <ol style="list-style-type: none"> 1. Software 2. CPU Diagnostics 3. Display Diagnostics 4. Communications 5. Cloud 6. GPS 7. ADS-B In 8. Flow Diagnostics 9. Lightbar Diagnostics 10. Software Versions 11. IO Diagnostics
<p>6 Pattern Swath</p>		<p>Users can pick specific patterns, related settings, and the current swath width using the Pattern Swath menu. This button will lead a user to the following functions.</p> <ol style="list-style-type: none"> 1. Pattern 2. Swath
<p>7 Display</p>		<p>The Display menu is where the user picks system-wide settings like unit system and language. Here also is the setup for HotKeys and the screen display information for various Guidance Modes. Finally, the user can set the colors and behavior for items on the map and overall display settings like dimming and night mode. This button will lead a user to the following functions.</p> <ol style="list-style-type: none"> 1. Units Setup 2. Language Setup 3. Hotkeys 4. Screen Displays 5. Screen Control
<p>8 Lightbar</p>		<p>The Lightbar menu is where the user sets the data to be displayed on the lightbar. Other overall settings, like dimming are set here too. This button will lead a user to the following functions.</p> <ol style="list-style-type: none"> 1. Lightbar Display 2. Lightbar Setup
<p>9 Advanced</p>		<p>Advanced Menu contains some less often used settings and functions. One menu of note here is visibility. The Falcon attempts to show only information pertinent to each user. For instance, all Falcon Pros can operate a Transland Meterate, but turning off the visibility for Meterate will hide that setting everywhere, thereby reducing unnecessary information. Otherwise, a Satloc technician will help you pick options here as the need arises.</p> <ol style="list-style-type: none"> 1. Setup Profiles 2. Software Settings 3. Visibility 4. Authorize Unlocks 5. DB Maintenance
<p>10 Jobs</p>		<p>The Jobs menu allows loading of Jobs, selection of polygons and automatic pattern swathing selection through the Poly Pattern function. This is also the menu that imports job files from an external USB. This button will lead a user to the following functions.</p> <ol style="list-style-type: none"> 1. Job Selection 2. Import Job(s)

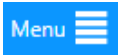
<p>11 Return</p>		<p>The return button in any menu steps back to the higher-level menu or from the Main Menu to the map screen.</p>
<p>12 Setup</p>		<p>This Setup button and a complementary “Menu” button on the Setup page swap back and forth for quick access.</p>
<p>13 Shutdown</p>		<p>This shutdown button is the best way to power off the Falcon. After confirmation, it will shut down the software, Windows, and gently power off all Falcon components. Once the Lightbar and Display go dark, it is safe to turn off the main power to the Falcon.</p> <p>Note: The left-most LED on the display will remain green as long as power is supplied to the Falcon; the rest will turn off during this power-down routine. Once shutdown has started, the only way to start the Falcon is through a complete power-off and power-on cycle.</p>
<p>14 Exit to Windows</p>		<p>Occasionally, the user may need to interact with Windows. After confirmation, this will shut down the Falcon software. Falcon can be relaunched through an icon on the main Windows screen.</p>
<p>15 Menu (takes to Moving Map Screen)</p>		<p>This menu button will take a user straight to the Moving Map Screen</p>

1.8 NAVIGATING SUBMENUS

From the Main Menu, submenus will appear when menu buttons are selected. The different submenus display a context-sensitive list of options for the function selected.

- 1 The left-hand side of the screen represents second level menu choices.
- 2 A gray bar will appear when there are more second level menu choices that need to be scrolled through to view.
- 3 The highlighted button (button that is a lighter blue), indicates which second level menu is currently selected.
- 4 Third level menu buttons appear based upon the second level menu button that is selected on the left-hand column.
- 5 Small triangles at top and bottom indicate third level menu choices that need to be scrolled through to view.

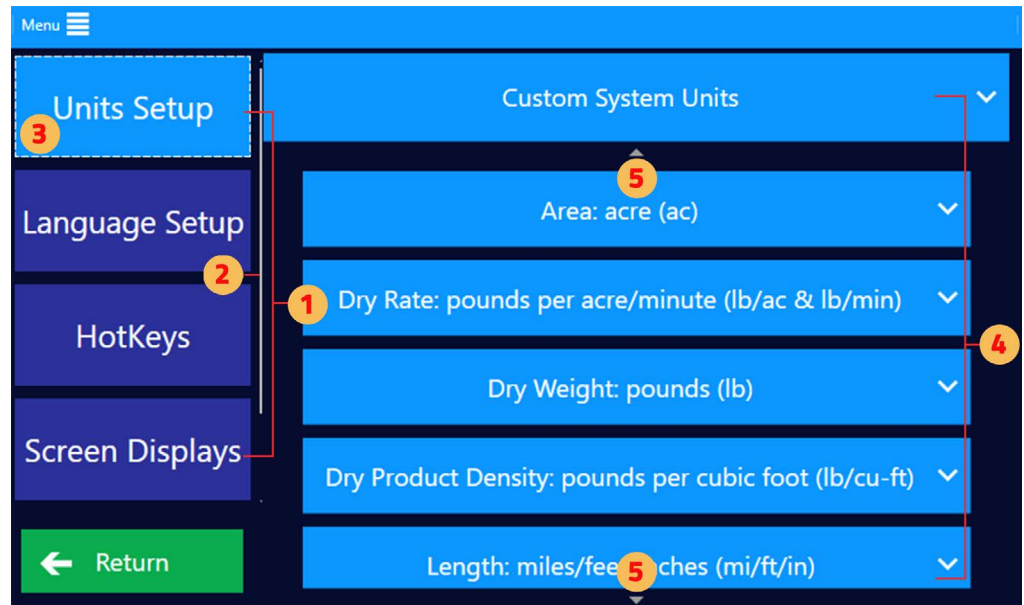

1.9 SYSTEM DIAGNOSTICS



On the Main Menu, a red box will surround the Diagnostics Menu button when there is a system error. Inside the Diagnostics submenu, red boxes again indicate which system is experiencing a problem. Clicking on the button with the red box will reveal the error's details. This information will help troubleshoot and resolve the issue.

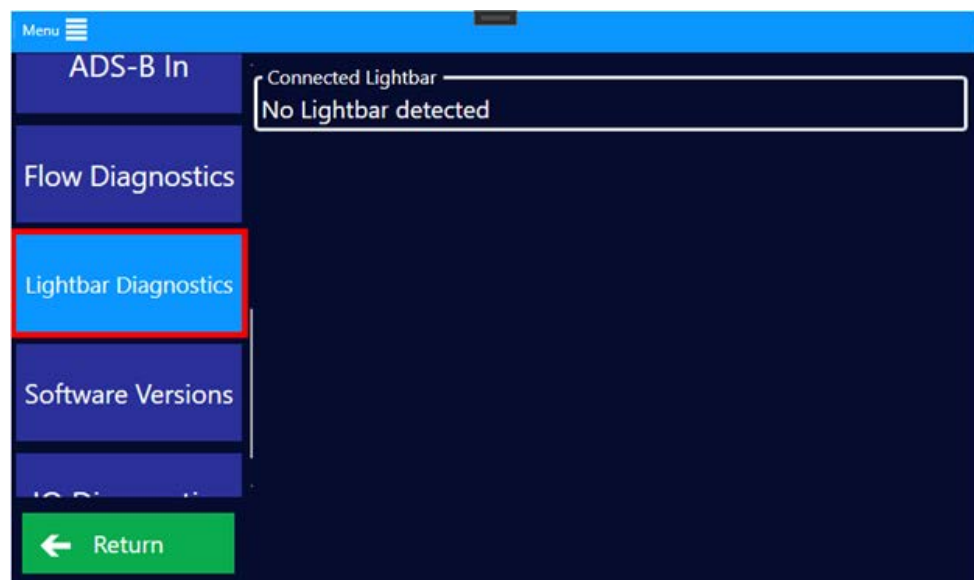

1 Software Versions

The Software Versions submenu lists all the software and firmware versions of the Falcon's components. This includes the versions for the Falcon software, CPU's LPC, Display, FTDI Communications, connected flow controllers, and connected lightbars. A Satloc technician often asks for this menu when troubleshooting a pilot's unit.

1

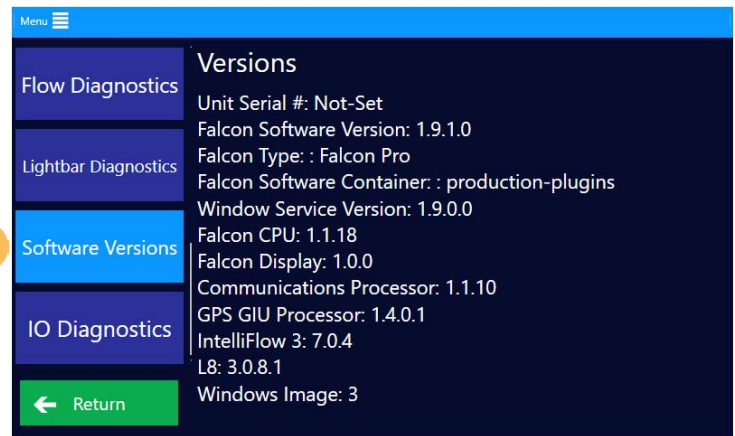

2 CPU Diagnostics

The CPU Diagnostics submenu, through the 'Status' button, shows the temperature data and health of the Falcon CPU.

The 'Information' button displays the CPU's LPC firmware and hardware versions.

2

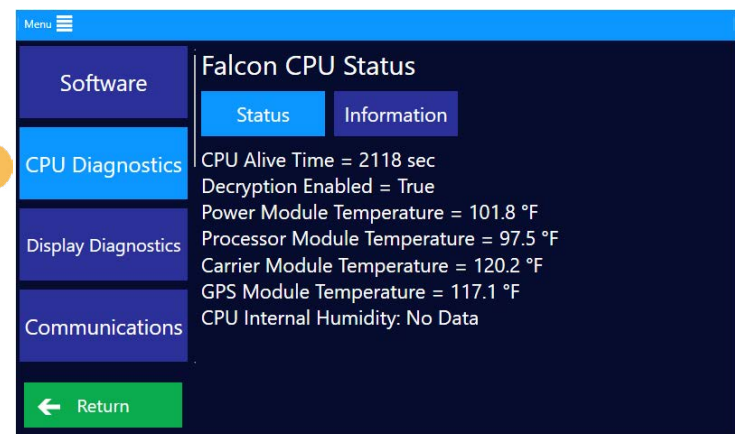

3 Display Diagnostics

The Display Diagnostics submenu, through the 'Status' button, shows the status and health of the connected Falcon display.

The 'Information' button shows the Falcon display firmware and hardware versions. Under the 'Information' area, the 'Reset Display Processor' button can reset the display if an error occurs.

3

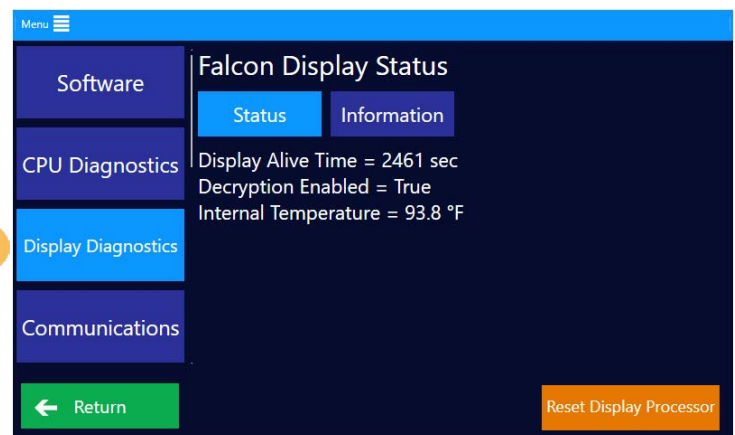

4 Communications

The Communications submenu, through the 'Status' button, shows the status and health of the Falcon's FTDI communication processor.

The 'Information' button displays the FTDI's firmware and driver versions. The Log Communication for 60 Seconds can be used to save the FTDI's processing information to a log file. A Satloc technician may ask you to log this information for troubleshooting purposes. The Reset Communication Processor button can be used to reset the FTDI processor if an error has occurred.

4

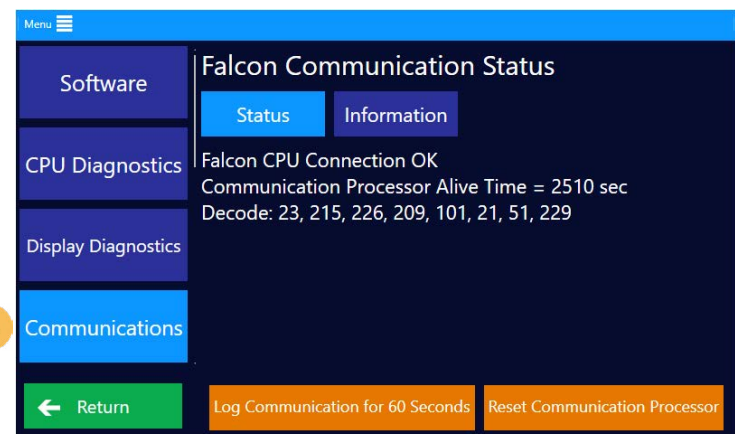

5 Cloud

The Cloud submenu shows the status of the Falcon's connection to the internet and the Satloc Cloud. This submenu box may be highlighted in orange if the unit has lost internet connection.

5

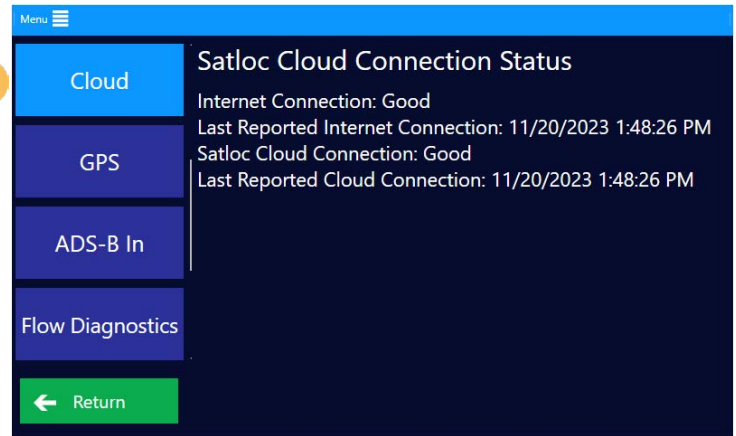

6 GPS

The GPS submenu, through the 'Status' button, shows the status and connection of the Falcon's GPS.

The 'Navigation' button shows more details, such as if the Falcon navigation is running on GPS Only or GPS with IMU data.

The 'Information' button displays the GPS's GIU firmware version and the CPS and IRS firmware versions if an IMU is connected.

6

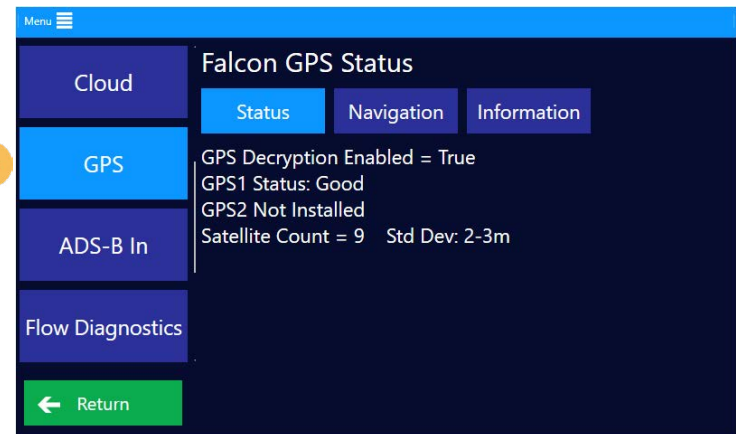

7 ADS-B In

The ADS-B In submenu, through the 'Status' button, shows the status and packet information for the Falcon's received ADS-B signals.

The 'Current Contacts' button displays all contacts currently being received and their information. It will also show if there are no current ADS-B contacts.

7

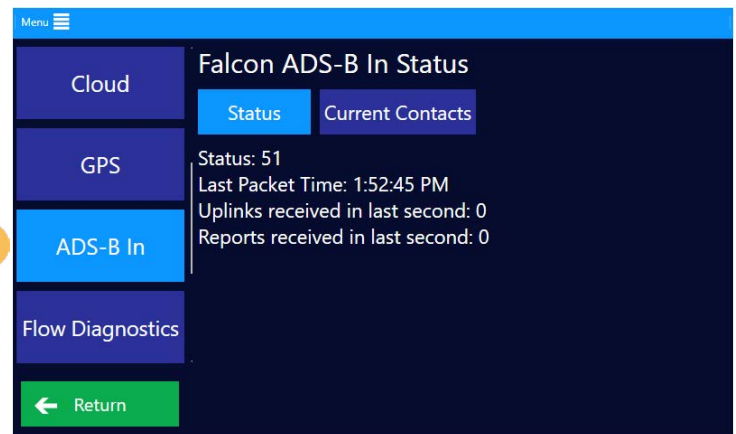

8 Flow Diagnostics

Through the 'Status' button, the Flow Diagnostics submenu shows the status and state of the connected flow control system, such as an IF3. This includes states such as Liquid Mode or Dry Mode and valve encoder position values.

The 'Start Test Valve Movement' button can be used to open a test menu and actuate the connection flow controller's valve. Press the Reset Flow Control Processor button to reset the connected flow controller if an error has occurred.

8

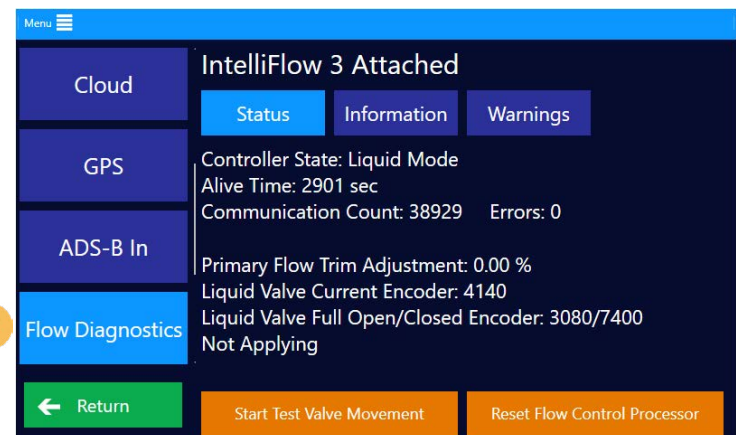

Flow Diagnostics, continued

Press the 'Move for (X) ms' button to change how long the valve will move for each test. Press the Open or Close Valve per Time buttons to actuate the valve open or close by the amount of time specified above. Press Full Open or Full Close to open or close the valve fully. Press the Go To Encoder Value button to specify a specific encoder value and move the valve to that position. When testing is finished, press Stop Test Valve Movement. (Other menu options will be disabled until testing is stopped.)

Through the 'Information' button, the Flow Diagnostics submenu shows the firmware and hardware versions of the connected flow controllers and their temperature and voltage data.

The 'Warnings' button displays the current errors and warnings from the connected flow controller.

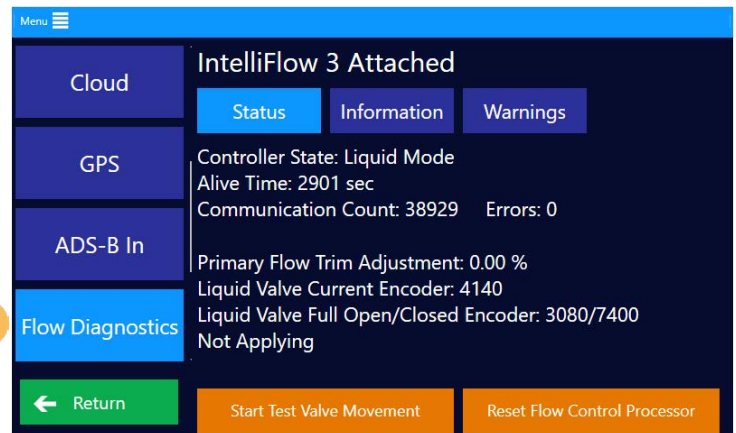
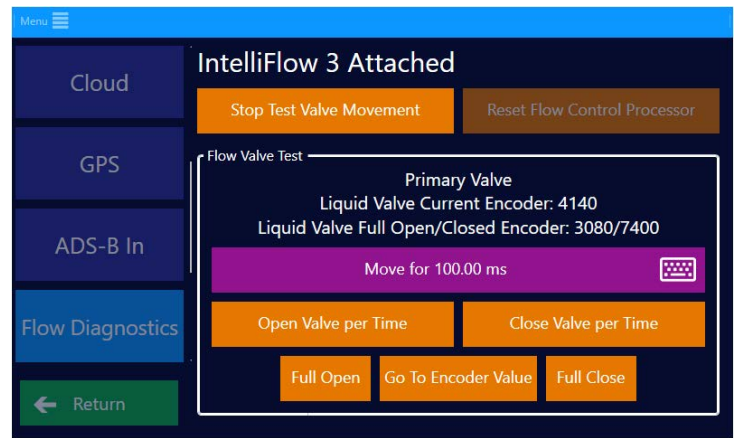

8

9 Lightbar Diagnostics

The Lightbar Diagnostics submenu shows the status and information of the connected lightbar. This includes the hardware and firmware versions. The 'Start Lightbar Test' button can start an LED test on the connected lightbar, which will run through a cycling pattern. Press Stop Lightbar Test at any time to stop the test. The Display Version button can be used to have the current lightbar firmware version display itself on the connected lightbar. The Reset Lightbar button can be used to reset the lightbar if an error has occurred.

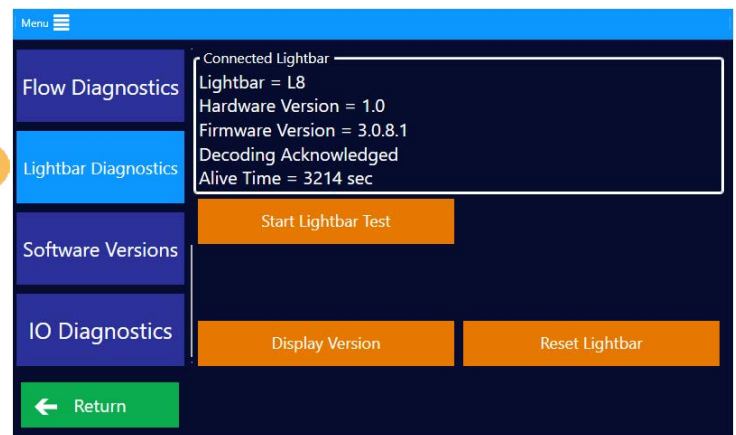

9

10 IO Diagnostics

The IO Diagnostics submenu is where a pilot can test their connected switches and TopHat controls without affecting the physical valves or components. When a switch is pressed or flipped, the corresponding box in this menu will change color (to red, for instance). For example, a pilot can flip their Gate/Boom switch, see the corresponding box change color, and flip it back without actually applying or "painting." This is a helpful menu when installing a Falcon onto an airplane to test the proper connections that are being made.

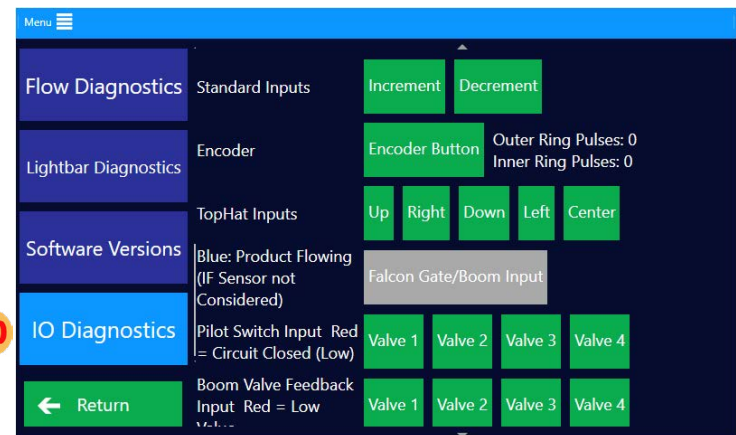

10

CPU Diagnostics

11

This will show you that the Falcon is properly connected and running. If it is not properly connected or running, the screen to the right displays what is shown as “No Heartbeat.” If there is no heartbeat, Satloc recommends contacting your local dealer.

11

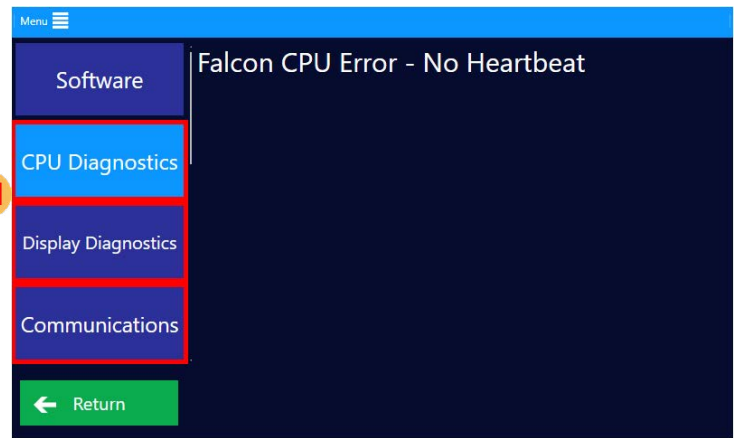

12

Lightbar Diagnostics

The Lightbar Diagnostics submenu shows the status and information of the connected lightbar. This includes the hardware and firmware versions. The ‘Start Lightbar Test’ button can start an LED test on the connected lightbar, which will run through a cycling pattern. Press Stop Lightbar Test at any time to stop the test. The Display Version button can be used to have the current lightbar firmware version display itself on the connected lightbar. The Reset Lightbar button can be used to reset the lightbar if an error has occurred.

12

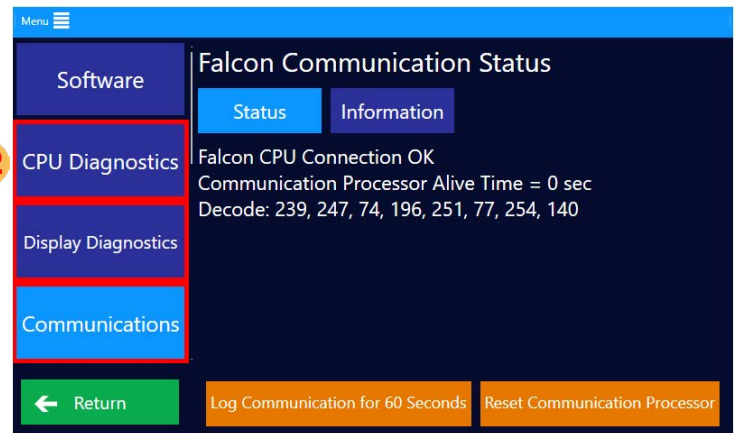

13

Software

The Software submenu shows the Falcon software status and health. This information is more for a Satloc technician.

13

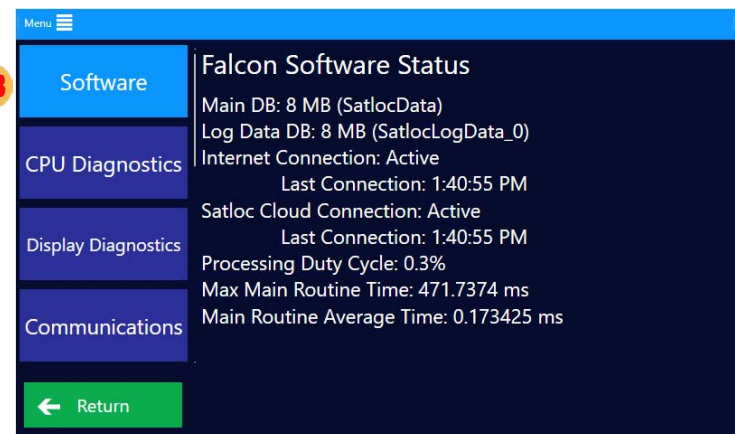





CHAPTER 2: GENERAL SETUP



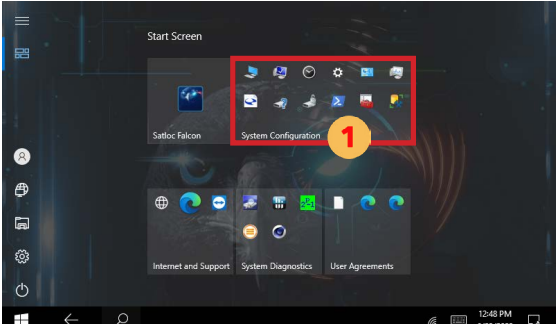
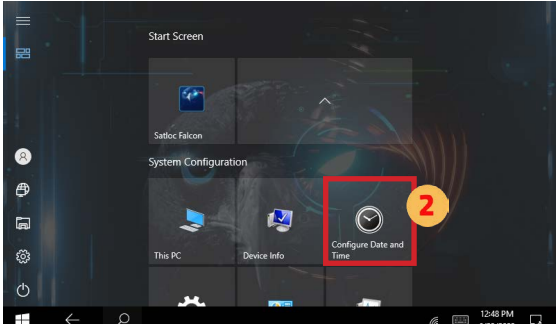
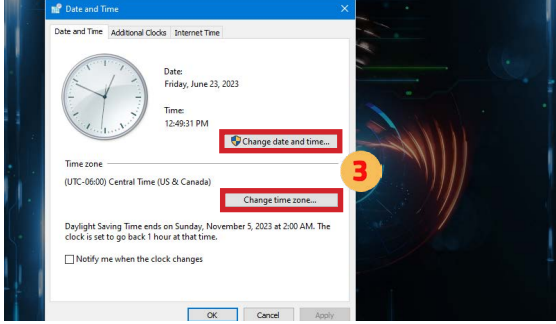

Complete these various tasks before you start working.

WHAT'S IN THIS CHAPTER!

- 2.1 Adjusting Regional Settings & Preferences
- 2.2 Visibility
- 2.3 Aircraft Setup
- 2.4 Explanation of Guidance Modes
- 2.5 Display Screen Setup
- 2.6 Lightbar Setup
- 2.7 Input Setup
- 2.8 ADS-B In Setup & Testing
- 2.9 Flow Control Setup & Testing

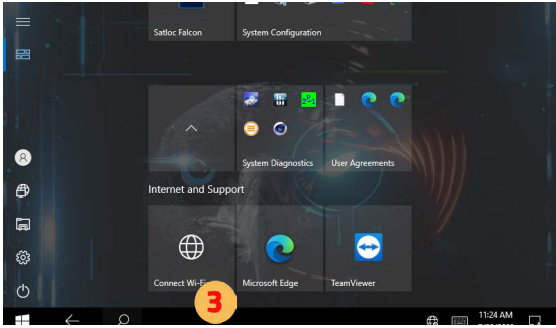
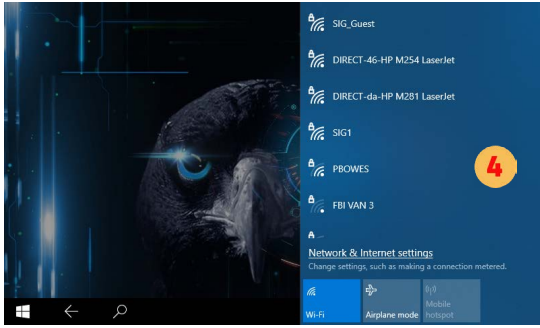
2.1 ADJUSTING REGIONAL SETTINGS & PREFERENCES

Field	Description and Navigation Path
<p data-bbox="110 338 261 436">Date, Time, & Time Zone</p>  	<p data-bbox="285 264 1518 323">Falcon/Falcon Pro is set to the default date and time in the Windows operating software. Setting the time is different than other systemwide settings. Please pay attention to the details.</p> <ol data-bbox="302 359 1511 621" style="list-style-type: none"> <li data-bbox="302 359 1511 422">1 On the Windows screen (“Exit to Windows” if the Falcon software is up), tap on the “System Configuration” group. If the screen for Step 1 doesn’t appear, tap the display to make it appear. <li data-bbox="302 443 708 485">2 Tap “Configure Date and Time.” <li data-bbox="302 516 1373 558">3 On the Date and Time window, press ‘Change date and time’ button and/or ‘Change time zone.’ <li data-bbox="302 590 1114 621">4 Make the changes to the date, time and time zone for user preferences.   
<p data-bbox="110 1444 261 1507">Connecting WiFi</p>	<ol data-bbox="302 1377 1495 1629" style="list-style-type: none"> <li data-bbox="302 1377 1495 1440">1 On the Main Menu of the Falcon software, select “Exit to Windows.” There is a “Minimize” option in addition to selecting “Yes” to exit.) <li data-bbox="302 1461 935 1503">2 On the Windows menu, select “Internet and Support.” <li data-bbox="302 1524 1195 1566">3 Scroll down and select “Connect WiFi.” This will open Windows’s WiFi menu. <li data-bbox="302 1587 740 1629">4 Select a WiFi network and connect.  

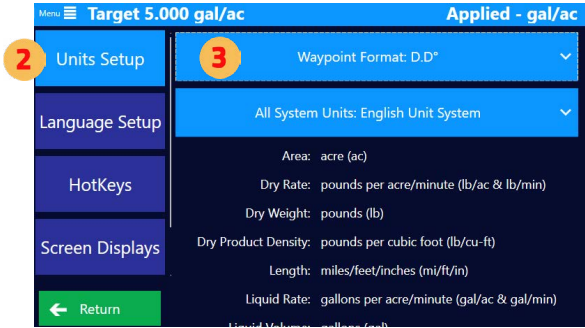
Field	Description and Navigation Path
	 
<p>Language</p> <p>English</p> <p>Português</p> <p>Español</p>	<p>There are three language options in the different Falcon models.</p> <ul style="list-style-type: none"> • English • Portuguese • Spanish <p>Set the desired language format by navigating this path: <i>Main Menu > Display > Language Setup</i></p>   <p>NOTE: If changing to a language other than English, it is recommended to restart the Falcon so that the text will format within the different spaces. After the initial restart, the wording will properly fit.</p>
<p>Coordinate</p> 	<p>You can display GPS coordinates as one of the following:</p> <ul style="list-style-type: none"> D.D° - decimal degrees (default) D° M.M - decimal minutes D° M' S.S - decimal seconds <p>Set the desired coordinate format by navigating this path: <i>Main Menu > Display > Units Setup</i></p>  

Global Unit

Falcon/Falcon Pro uses U.S. standard units (such as feet and pounds) as the default. Use the Global Units field to change this setting to Metric or Nautical. You can also assign units to individual data types (such as speed and area) in the Units Advanced Setup window.

Set the desired coordinate format by navigating this path: *Main Menu > Display > Units Setup*

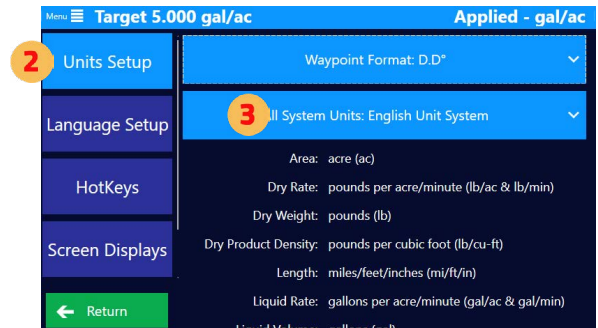

If 'Custom System Units' is selected, press the drop down for a specific unit and choose desired unit type.

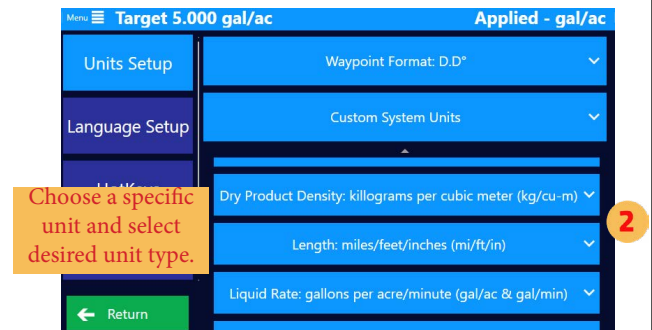

Swath Line Extension Beyond A|B

For rectangular fields where every pass is the same length as the A|B line, an extension of 0 is perfect. However, for odd-shaped fields and wind conditions where subsequent passes need to be longer than the A|B line, the Falcon can extend the drawn swath lines on both sides by this length. Set this by navigating this path: *Main Menu > Mapping > Map Setup > Swath Line Extension Beyond A|B*



Visual Swath 'Paint' Overlap

The Visual Swath 'Paint' Overlap is only a visual increase in width of swath paint on the screen. Users may increase this to remove the normal narrow swath gaps and only expose larger unintentional gaps. The logged data is not impacted by this setting. Only the paint on the Falcon display is altered. Set this by navigating this path: *Main Menu > Mapping > Map Setup > Visual Swath 'Paint' Overlap*

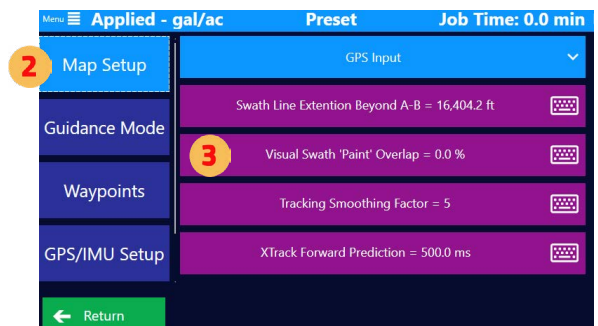

Tracking Smoothing Factor

(1 to 10, which is smooth to aggressive)

The Tracking Smoothing Factor is the quantity of points in a moving average of Tracking points to identify heading and ground speed. The balance should be specified here. Too few, and the Crosstrack and AOI indicators will be volatile due to natural variances in the GPS data. Too many, and the Crosstrack and AOI will be very smooth but will lag and not be as responsive to pilot correction. This impacts the “feel” of the GPS guidance. Set this by navigating this path: *Main Menu > Mapping > Map Setup > Tracking Smoothing Factor*.

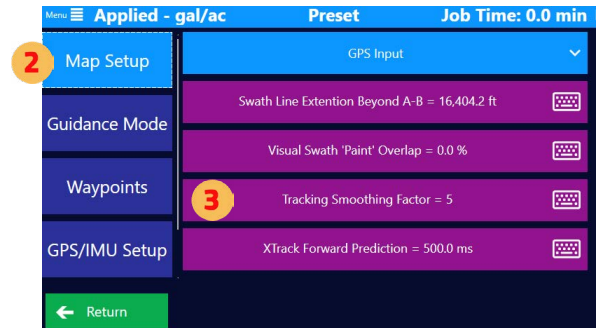
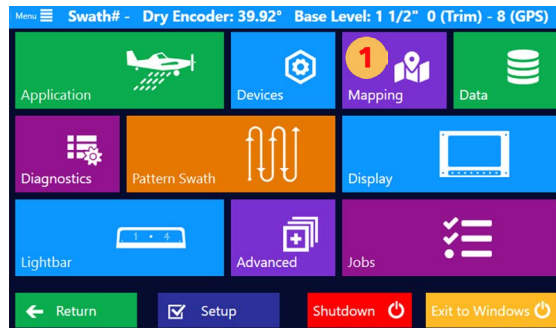

XTrack Forward Prediction

The XTrack Forward Prediction is a distance directly ahead of the current heading based on the Crosstrack indication. This means the XTrack indicator leads the actual plane by this value. This allows the pilot to respond timely. This impacts the “feel” of the GPS guidance also. Set this by navigating this path: *Main Menu > Mapping > Map Setup > XTrack Forward Prediction*.

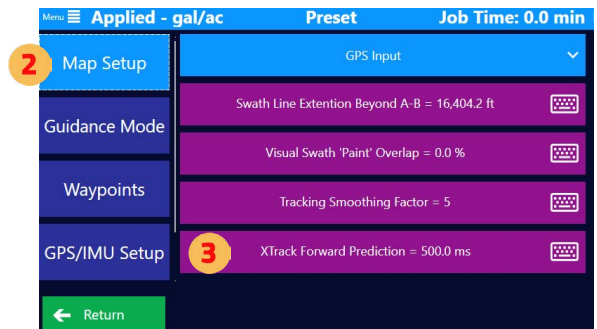

Screen Controls & Colors

In the Screen Control submenu, set the following. Set this by navigating this path: *Main Menu > Display > Screen Control*.

- Display Dimming
- Display Mode
- Screen Orientation
- Screen Motion
- Background Map
- Map Opacity
- Button Opacity
- My Plane Color
- Paint Color
- Partner Plane Color
- Guidance Line Color
- ADS-B Planes Color
- ADS-B Text Color
- Show Nearest Swath Line
- Clear Plane Track

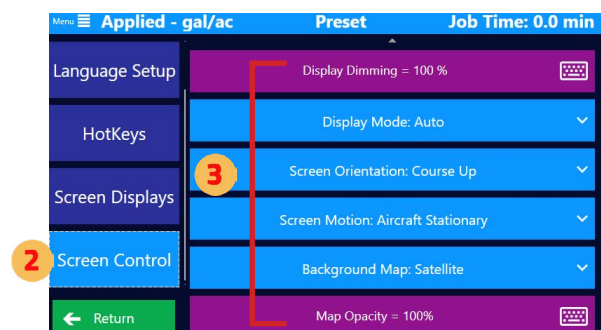
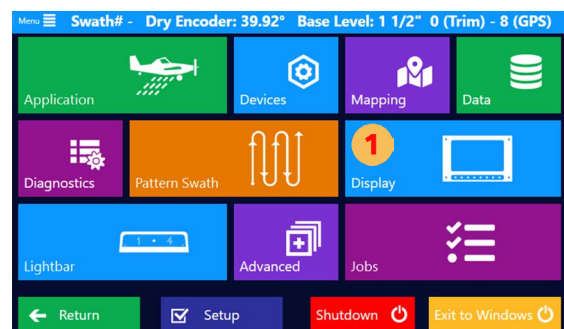

2.2 VISIBILITY

The Falcon is designed to present to the user just what is needed therefore hiding options and settings the user never expects to need. Some of this visibility is through the distinction between Falcon and Falcon Pro and some of the extra unlocks. But the user should check the visibility menu to verify only what is important to them is enabled to be visible. These settings can be changed at any time.

From the Main Menu, navigate to *Advanced > Visibility* and check the boxes for features and devices you want to make visible in other menus.

2.3 AIRCRAFT SETUP

Hopper Size

From the Main Menu, navigate to *Devices > Aircraft Setup* to specify the hopper size for this aircraft. These values can be used for hopper calculations.

Falcon Pro IMU Setup

Falcon Pros have an internal Inertial Measurement Unit (IMU) that “feels” the flight dynamics and helps smooth tracking when GPS is spotty. To perform, the IMU must know its orientation relative to the aircraft.

From the Main Menu, navigate to *Mapping > GPS IMU Setup*. Select the IMU orientation wizard and answer the questions. After the required power cycle to initialize the IMU with the new orientation information, the proper orientation can be verified. Below is an image of verifying the proper orientation.

For a tail-dragger on level ground, if the IMU is oriented correctly, the measured vertical G and Pitch and Roll angles should be as follows.

Vertical (G)	Actual: 0.99	Nominal: 1
Pitch (degrees)	Actual: 3.27	Nominal: Just above 0
Roll (degrees)	Actual: 0.64	Nominal: 0



WARNING

Failure to set the orientation or failure to answer the questions correctly will result in incorrect flight tracking information.

2.4 EXPLANATION OF GUIDANCE MODES

The Falcon allows the user to specify what information is displayed on the screen and lightbar, what buttons are available on the screen, and how to handle systems inputs specific to the immediate mode of flying. These modes are called Guidance Modes.

1. Liquid
2. Dry Gate
3. Dry Metered
4. Ferrying

When guiding to a polygon or waypoint, the system automatically switches to Ferrying Guidance Mode, updating the display, buttons, lightbar, and inputs accordingly. As the plane approaches the destination or upon pilot action, the Guidance Mode is switched to the current application mode: Liquid, Dry Gate, etc.

Specifically, there are four user setup areas that the Guidance Mode impacts. These are discussed in more detail later, but understanding the Guidance Mode concept is important initially.

- Screen Display (Information and Buttons at top and left)
- Lightbar Display
- Hotkeys
- Inputs (Encoder, Extra GPIO, TopHat, etc.)

In each area, the user can create any number of setups naming them whatever they want. From these, one setup can be designated as the “default” for each possible guidance mode.

In this example, the pilots have created three setups for the Input. The names below are extra-long to explain this example better:

- Pilot A Input Preferences for Dry
- Pilot B Input Preferences for Dry
- Pilot A Input Preferences for Liquid

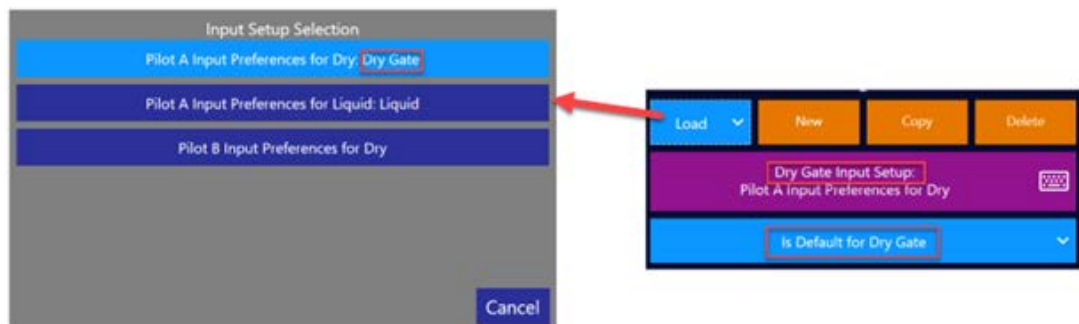

Here the two pilots have different preferences on how the inputs should be treated in Dry Gate mode, so they have saved unique Input setups. Currently the Pilot A version is set to the Dry Gate default. When the Falcon’s Guidance Mode switches to Dry Gate, the Pilot A Input Preferences for Dry will be loaded automatically.

Pilot B could load his dry setup manually, or set his to default instead. **Note:** there is no default selected for Ferrying. When switching to Ferrying Guidance Mode, the Input settings will remain unchanged from their current state.

Satloc recommends setting up a default for Ferrying and each likely application mode.

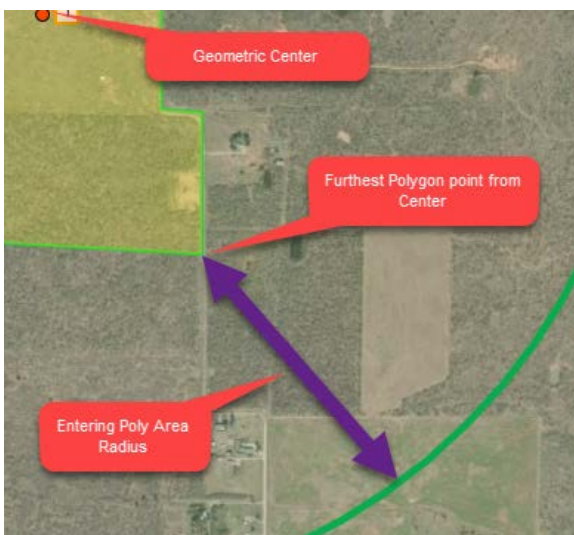

When the Falcon guides the pilot to a waypoint or polygon, the user can manually switch the Lightbar, Display, Hotkeys, and Inputs to the proper application mode, by an on screen button or increment. The Falcon will also make this switch automatically at a specific radius from the waypoint or polygon.

From the Main Menu, navigate to *Mapping > Guidance Mode*. Inside the Automatic Guidance Settings box, set the two Radii.



NOTE

For the Polygon radius, this is a radial distance beyond the furthest poly point from the geometric poly center.

2.5 DISPLAY SCREEN SETUP

Custom Displays for All Application Types



TIP

Satloc recommends setting up custom Display Settings for all likely application types (Liquid, Dry Gate, etc.) and a Display Setting for Ferrying.

Navigate to custom displays: *Main Menu > Display > Screen Displays*.

A pilot can enter and save multiple setups, so your name could be specific. For example, “Bob’s Liquid” or “Liquid for Forestry.”



NOTE

It is ideal for each Guidance Mode to have its own Display Setup. To have a particular setup loaded upon a specific Guidance Mode, select it to be that mode’s default.

Is Default for Liquid

Detailed instructions are located later in this section.

Top Display Customization

In the Top Display Area, three fields contain user-selected information. This is editable from the screen display menu and is part of the areas automatically updated when Guidance Modes change. See right-hand image to view an example of what the three fields in the Top Display area might look like.

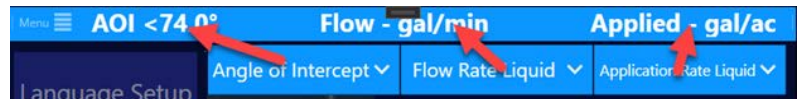

Note: Once in ‘Edit’ mode, navigation back to the menus is disabled until clicking ‘Done Editing.’

- 1 Tap ‘Display’
- 2 Tap ‘Screen Displays’
- 3 Tap ‘New’
- 4 Enter a display description name.
- 5 Press ‘Ok.’
- 6 Tap ‘Edit’

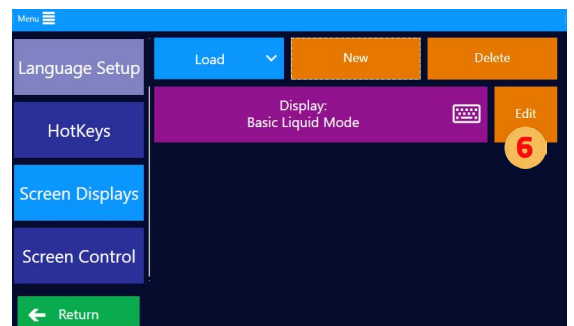
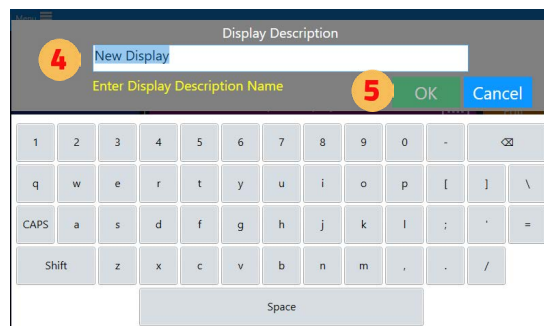
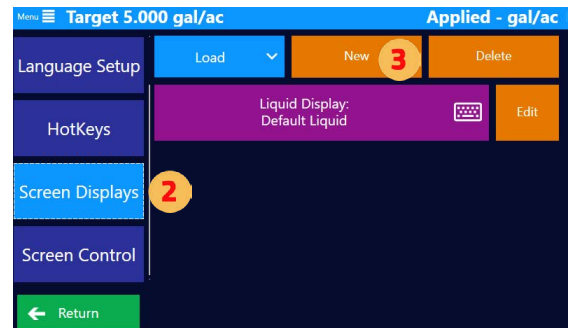
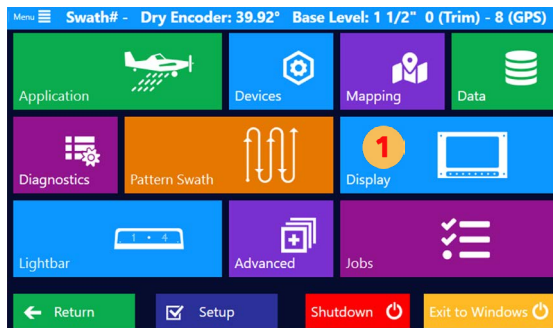

7 There are three buttons across the top labeled 'Blank' and have dropdown menus. Select one of the dropdown buttons to select a setting/function that you want displayed. These settings/functions will appear across the top of map screen (left, center, right).

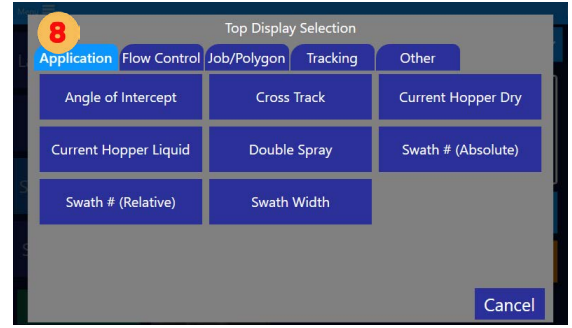

8 Choose the desired function/setting that you want to appear on the top display.

Left Display Customization

As explained earlier, at the left of the Moving Map Screen is a collapsible panel that contains user-selected information and buttons. This is editable from the screen display and is part of the areas automatically updated when Guidance Modes change.

The image below shows what will appear on the Moving Map Screen based upon what Left Display functions/settings were chosen. Notice how the image on the left shows some functions as simple text while others are have a blue button. Selections that are buttons typically allow the user to make quick edits to that information.



NOTE

Appendix B lists the functions and the definitions of what can be displayed on the top and left displays.



- 1 Tap 'Display'
- 2 Tap 'Screen Displays'
- 3 Tap 'Edit'
- 4 Tap 'Add'
- 5 Select 'Blank'
- 6 Choose Setting/Function
- 7 Select 'Insert Above' or 'Insert Below' to add a new setting/function. (The green list is the order of what will appear on the moving map screen.)
- 8 Select 'Blank'
- 9 Choose Setting/Function
- 10 Tap 'Done Editing' when finished. (Once in edit mode, navigation back to the menus is disabled until selecting 'Done Editing'.)

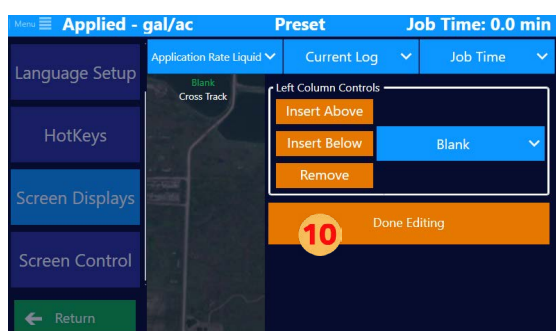
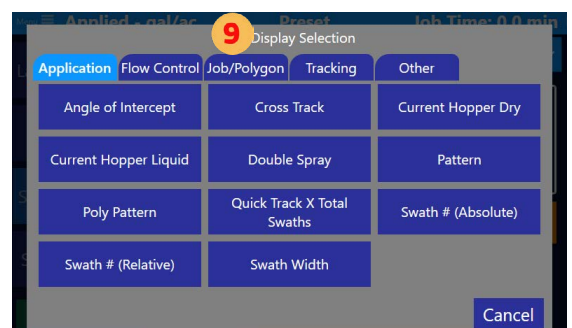
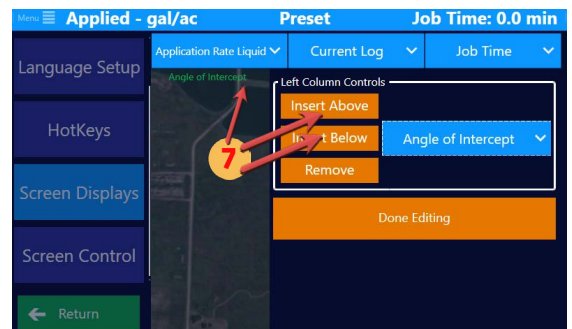
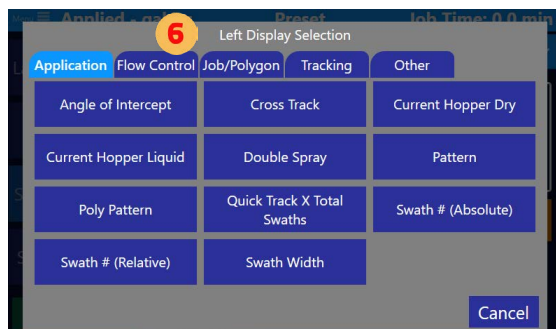
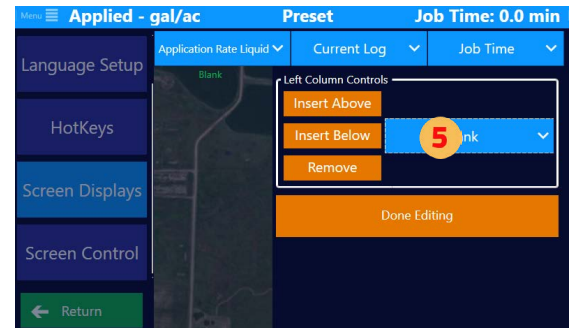
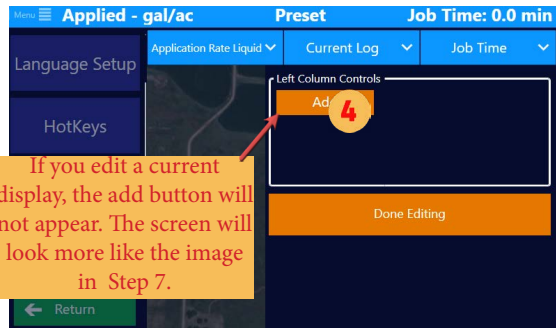
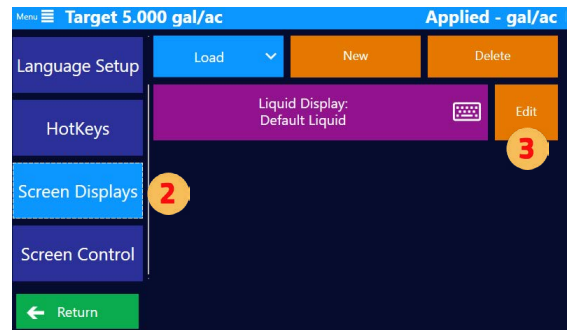

NOTE

If the quantity of settings/functions for the Left Display extends beyond the available space on the Moving Map Screen, that area can scroll with a finger swipe.

Setup Display to a Guidance Mode

As explained earlier in Section 2.4, all Falcon models allow the user to specify what information is displayed on the screen and lightbar, what buttons are available on the screen, and how to handle systems inputs specific to the immediate mode of flying. These modes are called Guidance Modes.

The benefit of this is whatever Guidance Mode is set for a particular application, those display settings will load when selected. For example, if a default is set for liquid application, whenever the Falcon is in Liquid Application Guidance Mode, this specific Screen Display will load.

Follow the steps below to set a particular setup to be loaded with a specific Guidance Mode.

- 1 Tap 'Display'
- 2 Tap 'Screen Displays'
- 3 Load the preferred display for a particular guidance mode
- 4 Select "Is Default for ..." button
- 5 Tap the desired application for the default display
- 6 Verify that the correct default is set to the loaded display

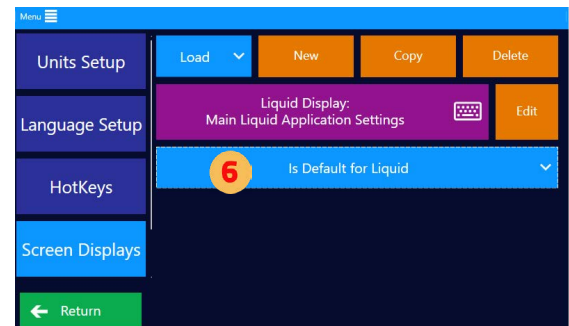
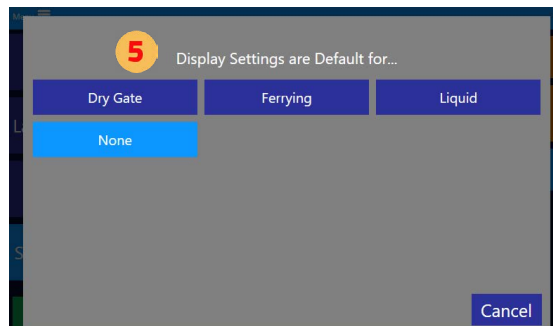
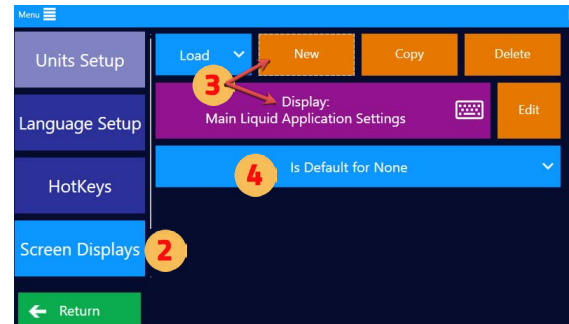

Custom Hotkeys for All Application Types

Satloc recommends setting up custom Hotkeys for all likely application types (Liquid, Dry Gate, etc.) and a Display Setting for Ferrying. These should be common actions required while in this particular mode.

From the Main Menu, navigate to *Display > Hotkeys*.

Tap 'New' and enter a name for this hotkey setup. A pilot can enter and save multiple setups, so your name could be specific: "Bob's Liquid" or "Liquid for Forestry."

Note: To have a particular setup loaded upon a specific Guidance Mode, select it to be that mode's default.

Is Default for Liquid

If the default is set for liquid applications, whenever the Falcon is in Liquid Application Guidance Mode, this specific Hotkey Setup will load. Creating a Hotkey Setup for each likely Guidance Mode is ideal.

- 1 Tap 'Display'
- 2 Tap 'Hotkeys'
- 3 Tap 'New'
- 4 Enter a hotkey set description name.
- 5 Press 'Ok.'
- 6 Select a hotkey slot dropdown menu.
- 7 Select one of the four main tabs at the top of the HotKey Selection screen and then choose an option for the slot.

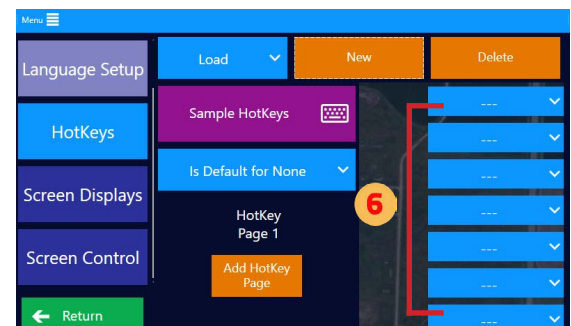
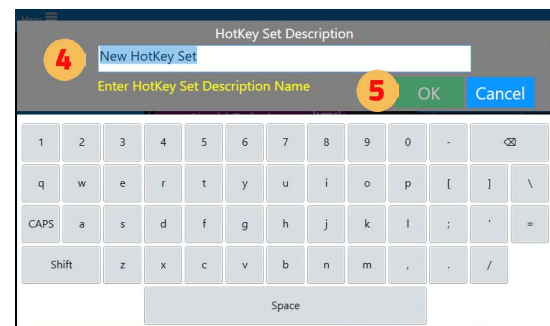
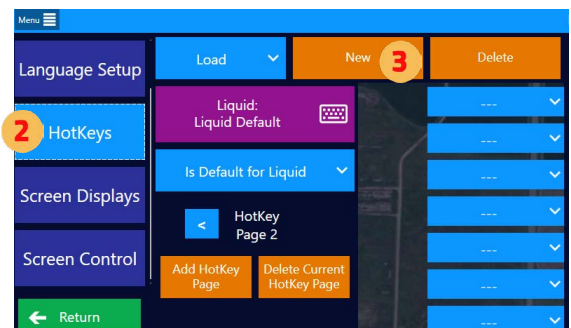

NOTE

Up to seven HotKeys can be displayed at a time; however, any number of HotKey pages can be created. Like smart devices, users can set up multiple pages of hotkeys and navigate between them as needed. Typically, the most commonly used buttons are grouped on page one of the HotKeys area, and less common buttons are on subsequent pages.

2.6 LIGHTBAR SETUP

Lightbar Display Fields Overview

The lightbar is composed of five (5) sets of lights, which are called display fields. These lights are highly customizable. When the lightbar starts, a blue chasing circle will appear in the middle of the lightbar screen, indicating it is searching for Falcon/Falcon Pro. The chasing circle stops when the lightbar is connected to Falcon/Falcon Pro software.

2 Top Bar

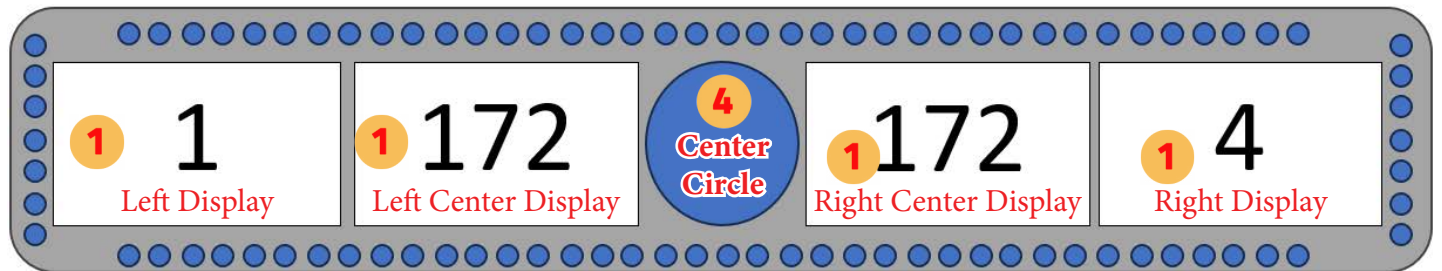

3 Bottom Bar

Side Bar

Side Bar

5

5

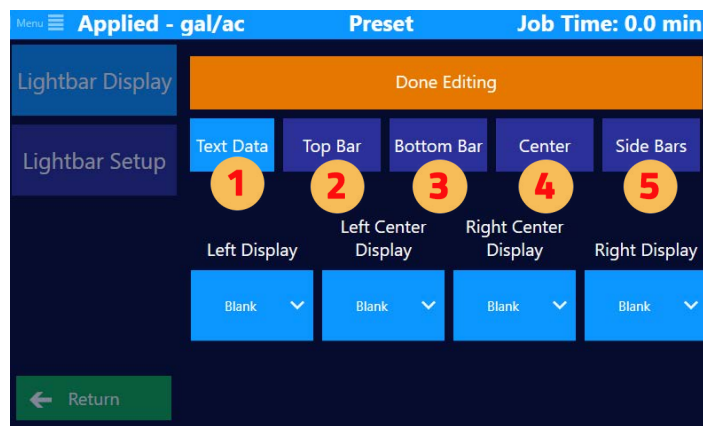

1 Display Fields & Text Data

The ‘Text Data’ area allows a user to customize the following display fields: 1) Left Display, 2) Left Center Display, 3) Right Center Display and 4) Right Display on the L8 Lightbar. The selection menu has tabs that help group the selection options. To the right is an image of what the screen looks like when choosing ‘Text Selection.’

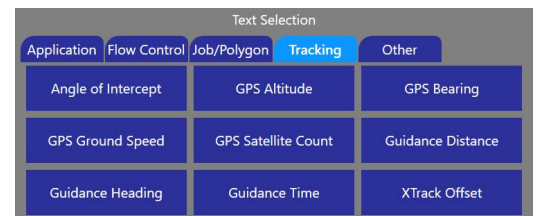

2 Top Bar

The ‘Top Bar’ consists of 45 colorful LEDs across the top of the Lightbar. Typically for application, this is set to XTrack Offset. For guidance, it is set to Guidance Offset. Users can specify what offset for each LED. **Note:** The Offset must be increasing in value from the center out. Click on a green or red box to edit the complementary pair of distances or angles.



On the right are images of what the screen looks like when editing the ‘Top Bar’ in a Falcon unit.

Also in the ‘Top Bar’ editing menu:

1. Whether offset is displayed as a solid bar extending from center or a single LED
2. Behavior of the vertical three LEDs at center, this in conjunction with the ‘Bottom Bar’

There is also an option for Xtrack Offset in cases where the user has picked a C pattern, sets an A|B, and is traversing over multiple swaths to set a C. This setting will prevent the XTrack Offset from swiping back and forth when it is not needed until the plane turns into a possible C swath. The default is 45 degrees meaning the XTrack will remain off until the AOI is within 45 degrees of parallel. At that point, the Xtrack LEDs will resume guiding the pilot into the nearest C Swath.

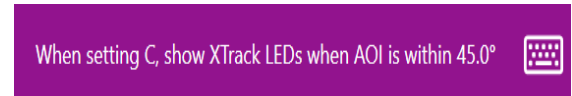

3 Bottom Bar

The ‘Bottom Bar’ is typically for application, set to the Angle of Intercept (AOI). During Guidance, it can be used in addition to or in place of the Top Bar Guidance Offset. Thirty-seven (37) colorful LEDs run across the bottom bar.

Users can specify what degree/offset for each LED. The LEDs are measured in degrees for AOI and Guidance. **Note:** the degrees must increase value from the center out. Click on a green or red box to edit the complementary pair of angles.

Also in the ‘Bottom Bar’ editing menu:

1. Whether offset is displayed as a solid bar extending from center or a single LED
2. Behavior of the vertical three LEDs at center, this in conjunction with the ‘Top Bar’

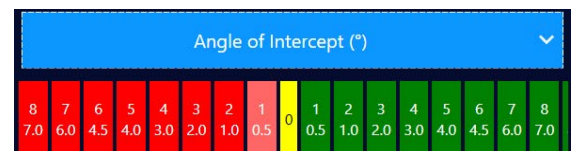
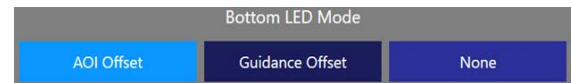

4 Center Circle

The Center Circle of colorful LEDs displays two kinds of information: trigger and obstacles. Here in the Lightbar settings, only the Trigger information is set. A user can set the type of visual trigger to ‘Distance,’ ‘Time,’ or ‘None.’

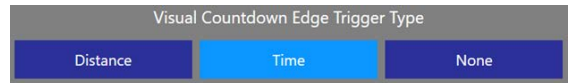

Distance and Time triggers cause a half-circle “smile” to visibly change, allowing the pilot to anticipate events. For the smile to work, it must be on Constant Rate Poly or Variable Rate Polygon. The smile starts with the side-most LEDs and continues to light LEDs to the middle so that the very Center LED lights at the precise trigger moment. For Distance, the Start and Stop triggers are set in length. For Time, the Start and Stop triggers are set in seconds.

5 Side Bars

The vertical blue LEDs at the extreme right and left can be used as visual guidance for vertical offset from an AgLaser Input. If AgLaser is selected, the user should enter the ideal application height and a smaller acceptable tolerance above or below that height. Within that tolerance, the blue LEDs will track similarly to a bubble level (only vertical). Outside that tolerance, the LEDs will scroll at increasing rates as the actual AgLaser height moves further from the ideal application height.

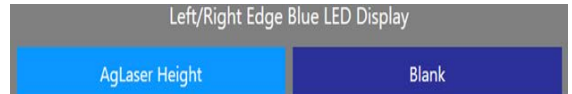

Lightbar Display

Navigate to custom displays: *Main Menu > Lightbar > Lightbar Display.*

A pilot can enter and save multiple setups, so your name could be specific. For example, “Bob’s Liquid” or “Liquid for Forestry.”



TIP

Satloc recommends setting up custom Lightbar Settings for all likely application types (Liquid, Dry Gate, etc.) and a Display Setting for Ferrying.



NOTE

Creating a Lightbar Display Setup for each Guidance Mode is ideal. To have a particular setup loaded upon a specific Guidance Mode, select it to be that mode’s default.

Is Default for Liquid

Detailed instructions are located later in this section.

Setup Guidance Mode for Liquid

- 1 Tap the 'Lightbar'
- 2 Tap 'Lightbar Display'
- 3 Tap 'New'
- 4 Type a name for the lightbar setup. Then, tap 'OK.'

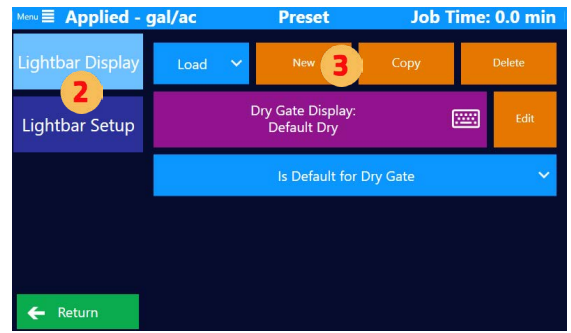

- 5 Verify that the Lightbar Display Setup is loaded for editing

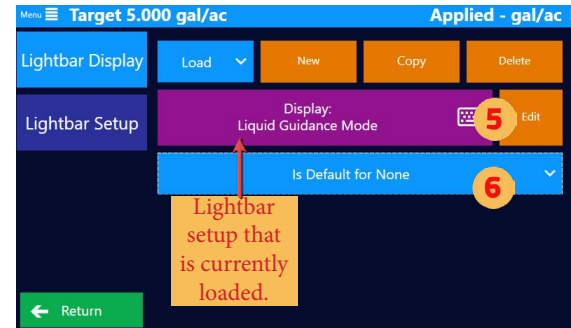
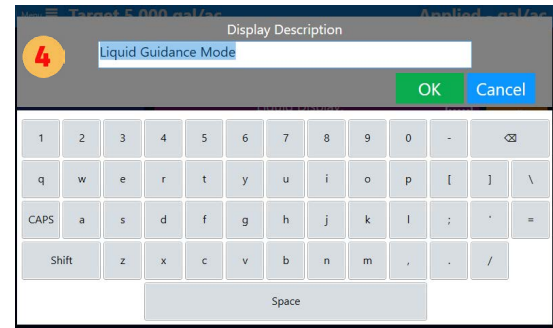

- 6 When loaded, Tap 'Is Default for Liquid'
- 7 Tap 'Liquid'

TEXT DATA FIELDS

- 8 Tap 'Edit'
- 9 Tap 'Text Data.' Then, tap to edit displays.

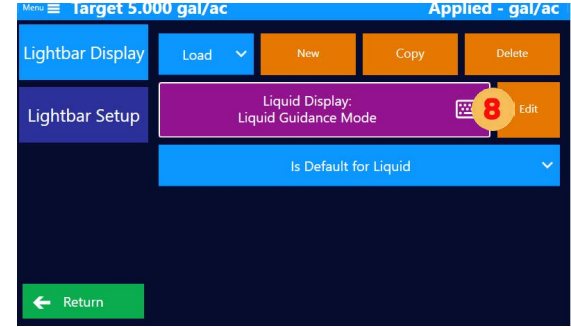
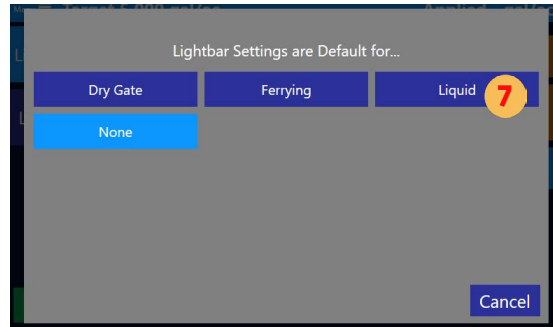

TOP BAR

- 10 Tap 'Top Bar'
- 11 Tap the long blue bar Tap blue selection button, often seen as the default 'Angle of Intercept'

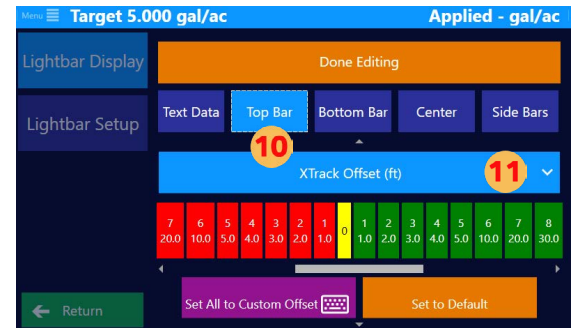
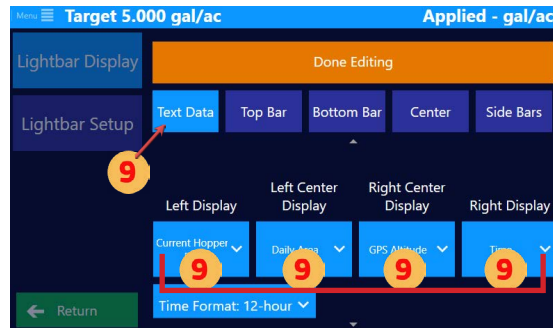

- 12 Select a Top LED mode
- 13 Tap on the colored bar to change distance

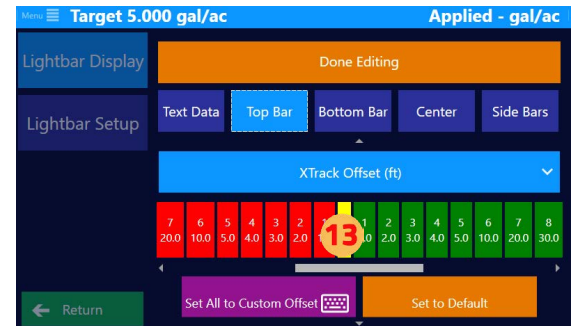
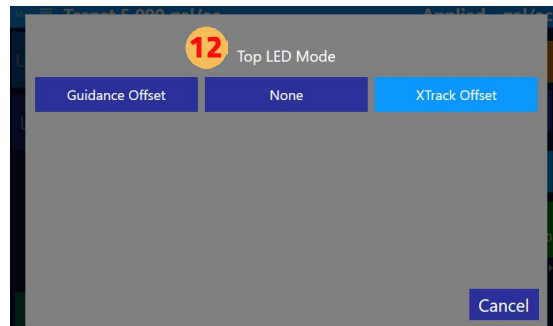

Set the distance from the center for LED. This automatically sets both sides. Then, tap 'OK.'

- 13 (Finishing up Step 13)
- 14 Tap 'Set All to Custom Offset' to set a distance between each LED. This distance will be applied to all LEDs.

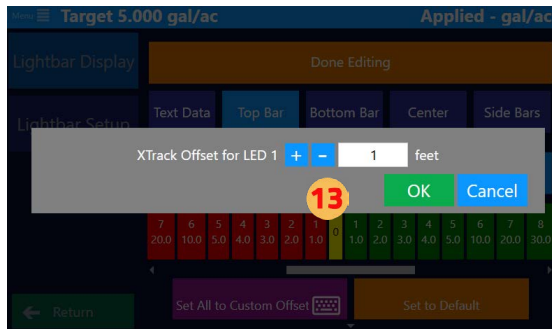

Tap 'Set to Default' to reset the distance between each LED back to default

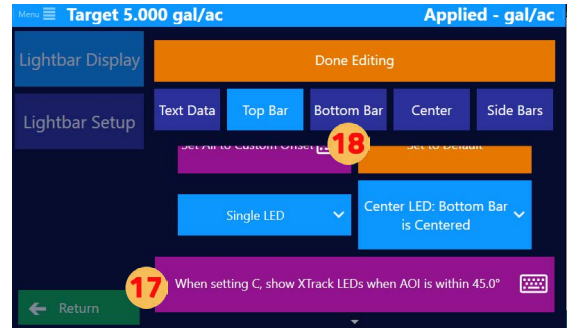
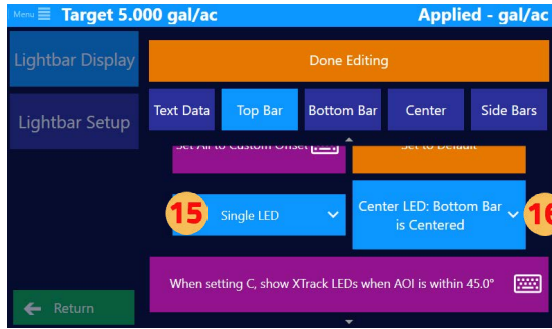

- 15 Tap 'Single LED' or 'Solid Bar' to choose a bar style

- 16 Tap 'Center LED' to choose the middle LED operation

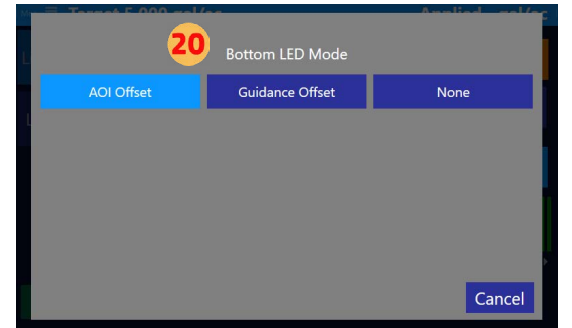
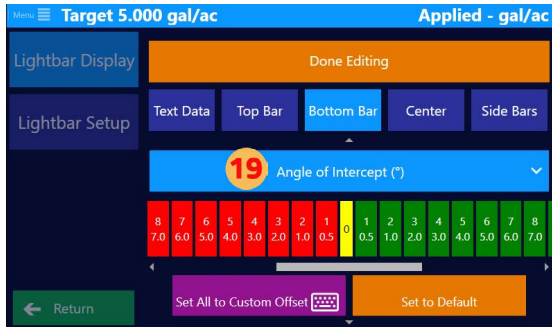

- 17 Tap 'When setting C, Show XTrack LEDs when AOI' to set degrees

BOTTOM BAR

- 18 Tap 'Bottom Bar'
- 19 Tap blue selection button, often seen as the default 'Angle of Intercept'

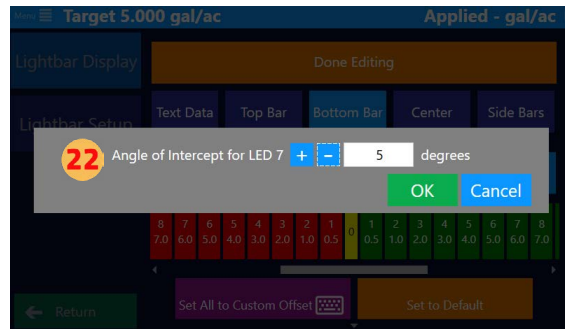
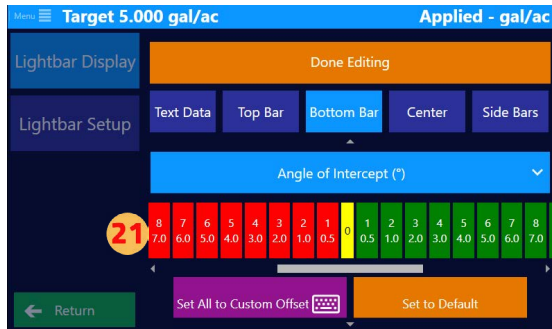

- 20 Choose Bottom LED Mode
- 21 Tap on the colored bar to set specific offsets for certain areas.
- 22 Set the distance from the center for LED. This automatically sets both sides. Then, tap 'OK.'

23 Tap 'Set All to Custom Offset' to set a distance between each LED. This distance will be applied to all LEDs.

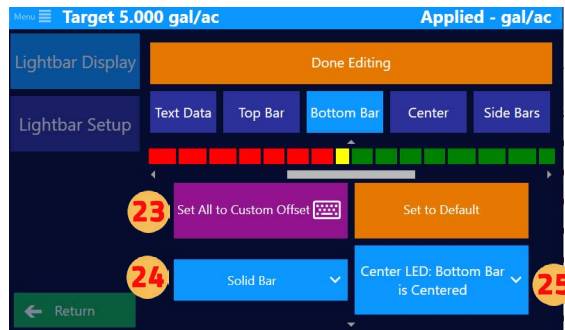

24 Tap 'Single LED' or 'Solid Bar' to choose a bar style

25 Tap 'Center LED' to choose the Bottom Bar LED operation

CENTER

26 Tap 'Center'

27 Tap 'Edge Trigger: None'

28 Choose 'Distance' or 'Time' for the visual edge countdown

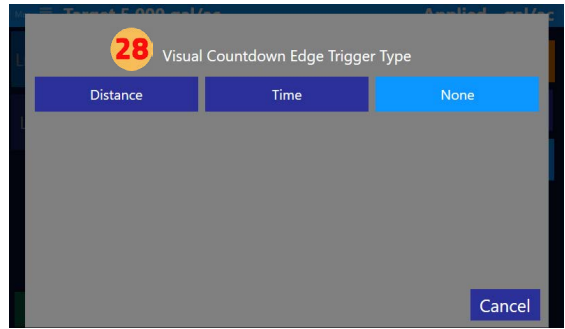

The next steps/ settings will depend upon which type was chosen for the visual edge.

Side Bars

29 Tap 'Side Bars'

30 Tap the long blue button to set left/ right edge for AgLaser Height

31 Tap 'Application Height'

32 Input application height and then tap 'OK'

33 Tap 'Application Height Tolerance'

34 Input application height tolerance and then tap 'OK'

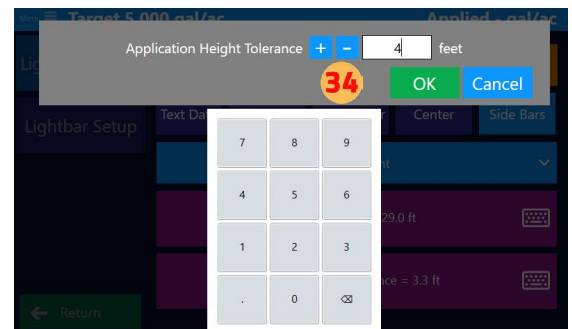
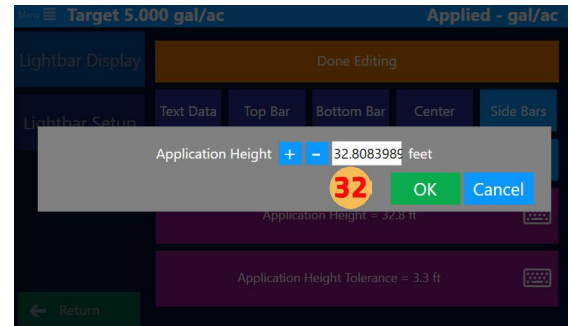
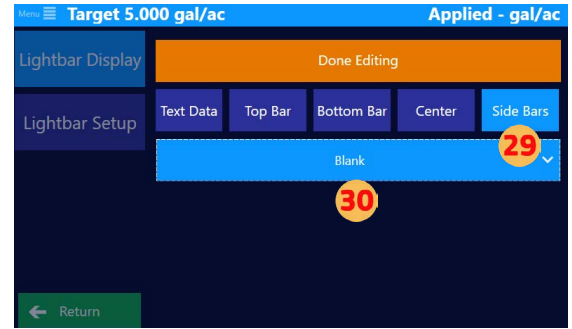
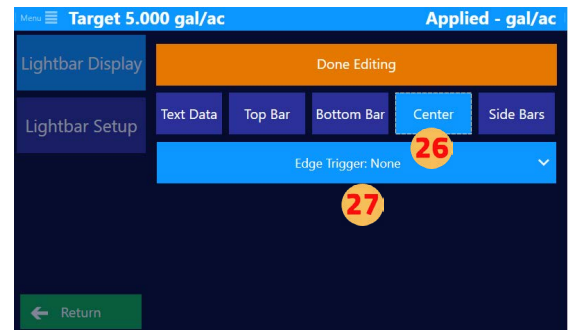
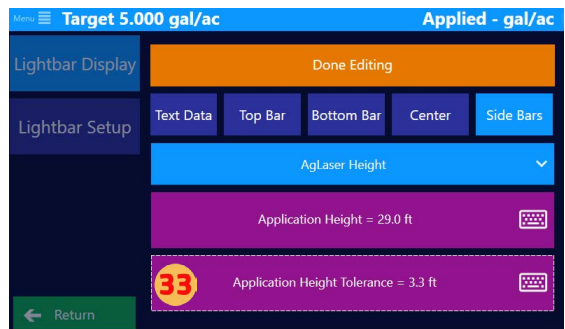

Lightbar Dimming & Warning Settings Setup

- 1 Tap the 'Lightbar'
- 2 Tap 'Lightbar Setup'
- 3 Tap on the following buttons to edit settings:
 - Text Brightness
 - Guidance Brightness
 - Color Profile for Center Circle
 - "Smile" Hold Time
 - Double Spray Blink Style

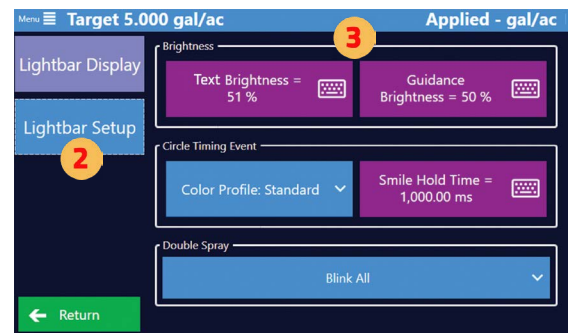
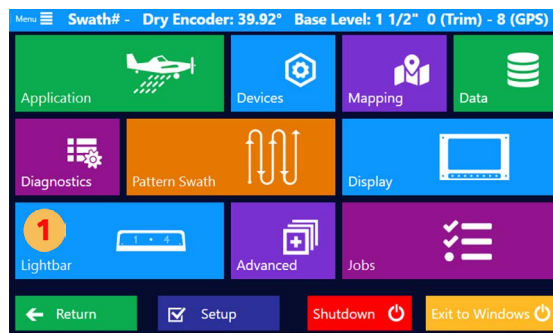

NOTE

A double-spray warning appears (if set to ON) when you apply on a previously sprayed area. It also appears when you come into contact with your previous swath width.

2.7 INPUT SETUP

Input Overview

Difference Between the Falcon & Falcon Pro

Falcon models only come with an outer encoder knob, which is often referred to as a single or basic encoder. Falcon models do not have the inner knob (no smaller knob) with a button. Thus, in the Falcon Basic Software there is only one (1) option to set the encoder.

Falcon Pro models come with a dual encoder knob, also referred to as a multi-function, encoder knob.



TIP

The various inputs on the Falcon are programmable and settable per Guidance Mode (like the Lightbar, Display, and Hotkeys.)



NOTE

A user can choose to upgrade the Falcon Encoder Knob to the Falcon Pro Encoder Knob. First, contact your dealer to purchase the hardware upgrade equipment (cable, inner knob, button). Second, connect the software by following this path: *Main Menu > Advanced > Visibility*. Then, click on the 'Dual Encoder Cable' box.



NOTE

Chapter Four of this manual explains basic functions of the single and dual encoder knobs.

Falcon Input Setup

The Falcon models, which come with a single encoder knob, have three default input signals: Increment, Decrement, and Encoder Knob. With only these three inputs, a Falcon user will most likely not have different settings for different Guidance modes. Due to the limited capabilities, the increment Button is set to Increment and Decrement Button to Decrement. The single Encoder knob should probably be set to dim both the display and Lightbar.

Follow this path to set up the single encoder knob: *Main Menu > Devices > Input*. Then, scroll to the 'Standard Buttons' and 'Encoder (while on moving map)' section. Below is an image of the recommended setup.

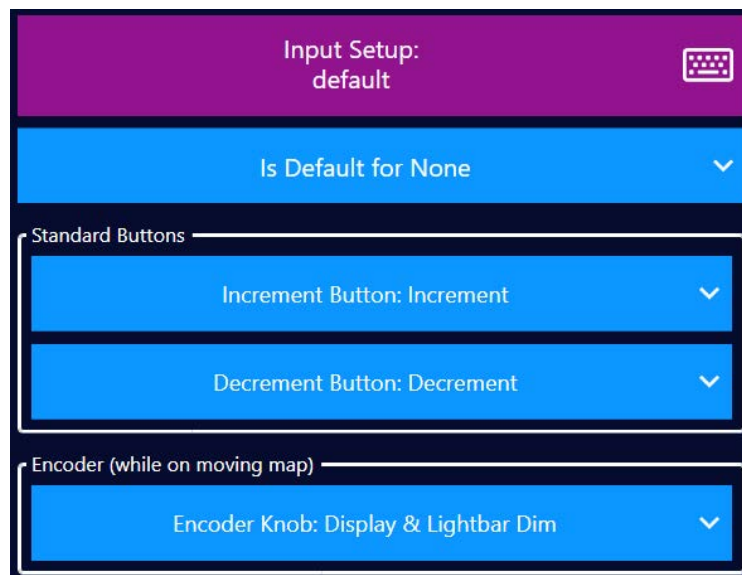

Falcon Pro Input Setup

The Falcon Pro models have Increment, Decrement, a multi-purpose Encoder Knob, and top hat inputs. The dual encoder knob allows five (5) different selections. The dual encoder has a button attached to the smaller inner knob. Spinning either knob while this button is pressed down (depressed) or simply clicking this button has unique actions in addition to simply spinning the outer and inner knobs. All of these settings only apply while on the moving map screen.

Follow this path to setup the dual encoder knob: Main Menu > Devices > Input. Below is an image of the five (5) programmable selections for the dual encoder knob.



TIP

For a visual of how-to use and customize the Falcon Dual Encoder knob, visit Satloc's YouTube channel or click this [link](#) to take you directly to the video.



Setup Encoder Knob as a Default for Different Guidance Modes

- 1 Tap 'Devices'
- 2 Tap 'Input'
- 3 Select 'Is Default for None'
- 4 Choose a Guidance Mode for the Input
- 5 Choose settings for 'Standard Buttons'
- 6 Choose settings for 'Encoder'

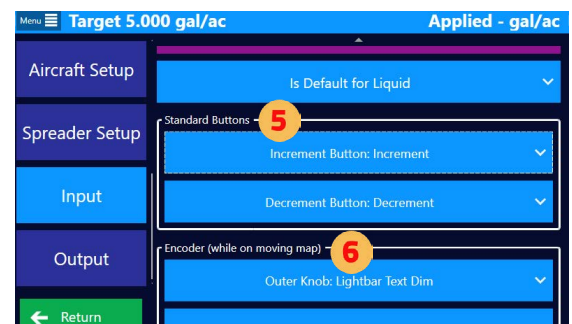
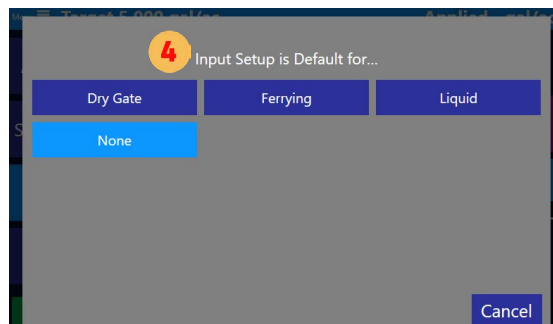
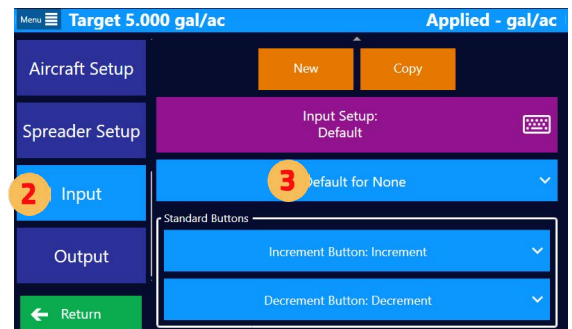

2.8 ADS-B IN SETUP & TESTING

The Falcon models are equipped to give on-screen and Lightbar indications of nearby contacts.



Not every nearby aircraft is equipped with ADS-B Out. ADS-B In provides information to pilots that help prevent accidents. HOWEVER, ADS-B In does not replace pilot best practices, pilot situational awareness, and properly functioning equipment.

ADS-B In Setup

Navigate to ADS-B In settings by following this path: *Main Menu > ADS-B In Setup*

- 1 If your plane is equipped with ADS-B Out, select 'Ignore My Call Sign' and enter your transmitted call sign in the text field.
- 2 Tap 'Contact Limit' to set contact distance limit. The ADS-B device will receive air-to-air contacts in your immediate area and rebroadcast contacts from nearby ground stations for an extensive area. The Contact Limit input limits the On-Screen contacts to a square extending this distance from your location.
- 3 Tap 'Lightbar Alert Radius' to set distance alert on lightbar.
- 4 Tap 'Contact Maximum Altitude Differential' to set altitude distance alert on lightbar.

Note: Alerts on the Lightbar are even further restricted. The Falcon creates a cylinder with your aircraft in the center. Any contact within the Lightbar Alert Radius and the Contact Maximum Altitude Differential (above and below your current altitude) will show on the Lightbar circle.

- 5 Toggle On or Off the 'Alert for Ground Contacts.' In the ADS-B data, this indicates contact is on the ground (not airborne). Turning this off would then ignore such contacts.

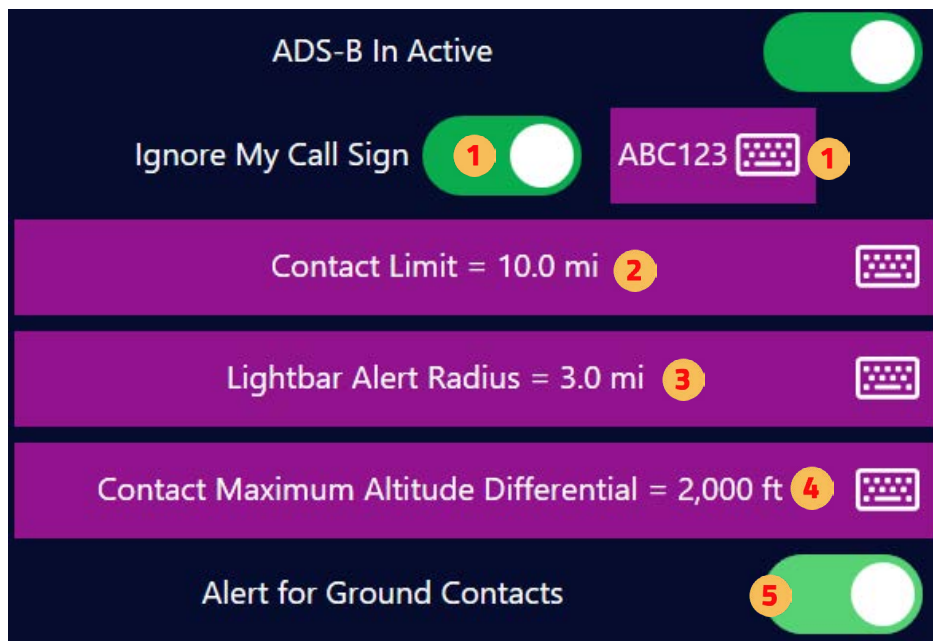

NOTE

On the Lightbar, a contact is identified with a single white LED in the relative direction to your heading. There are 18 such LEDs, so each represents 20 degrees. The chasing LEDs surrounding the contact LED indicate the urgency of the perceived threat based on the rate of change in distance. Contacts that are getting further away are slow blue-chasing LEDs. A contact whose distance is converging quickly results in fast red-chasing LEDs. The urgency colors change from Blue, Purple, Orange, and then to Red.

Testing ADS-B In

- 1 Tap 'Diagnostics'
- 2 Tap 'ADS-B In'
- 3 Tap 'Current Contacts'
- 4 Tap 'Return' twice to go to Moving Map
- 5 ADS-B contacts should appear on the screen. Zoom in and out of the screen to see more or less.

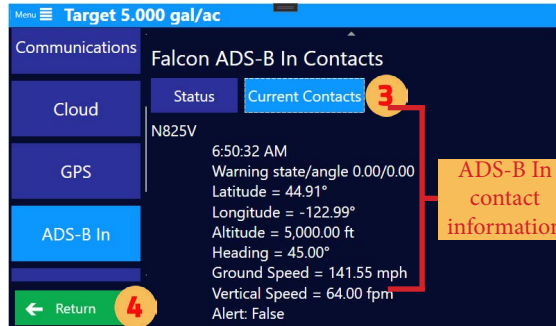
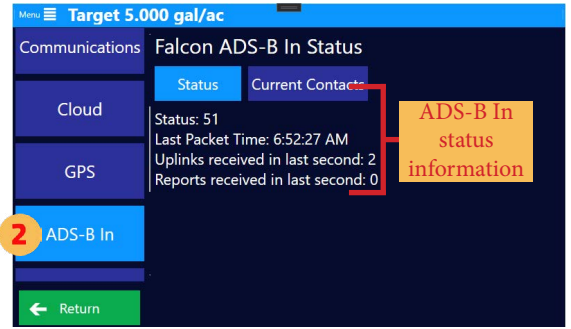

2.9 FLOW CONTROL SETUP & TESTING

Setting Up Flow Control for Liquid

- 1 Tap 'Application'
- 2 Tap 'Flow Control'
- 3 Tap the 'Flow Control Mode' (This might have the words "None", "Liquid", or "Dry Gate" after the colon in the button name.)
- 4 Select Application Mode
- 5 Tap 'Flow Control Type'
- 6 Select Application Type
- 7 Tap 'Flow Controller'
- 8 Select a Controller
- 9 Tap 'Target Application Rate'
- 10 Set a Target Rate. Then, tap 'Ok.'
- 11 Tap 'Return'

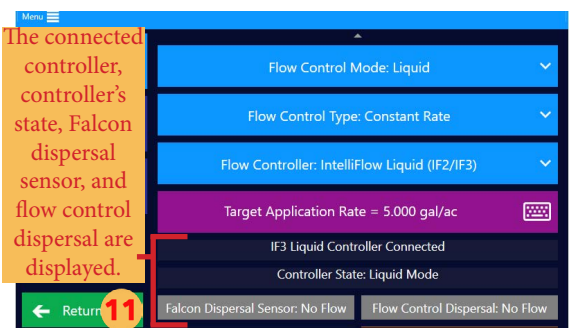
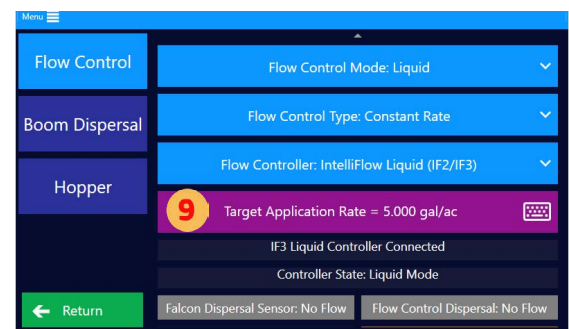
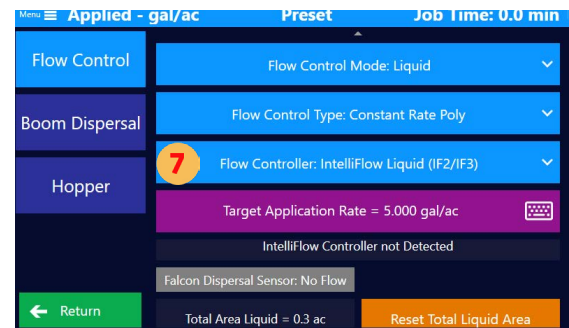
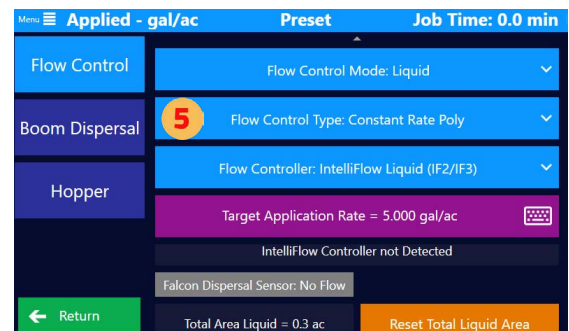
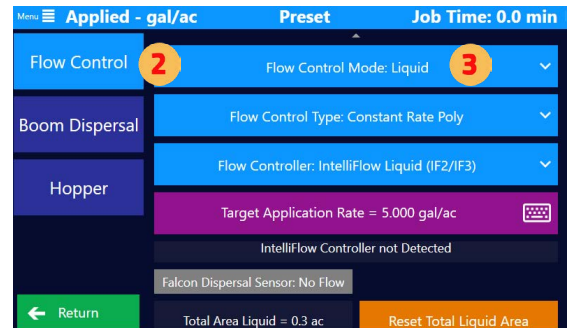
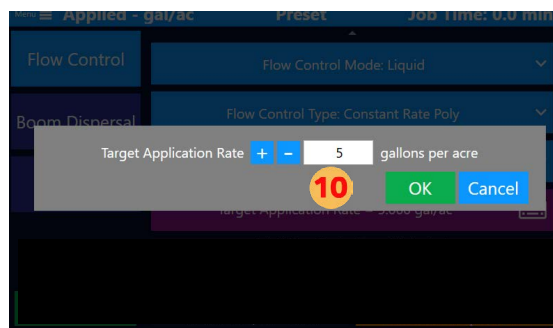
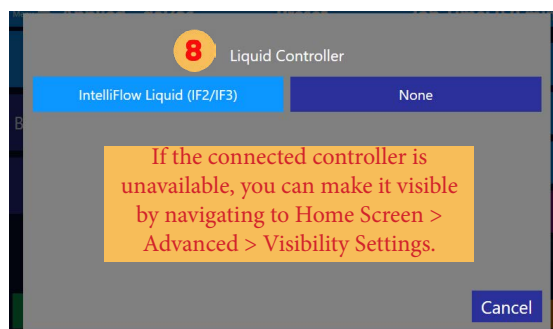
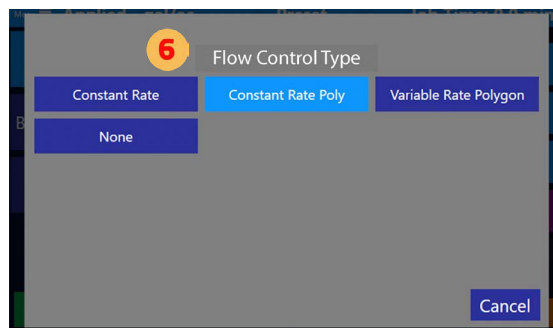
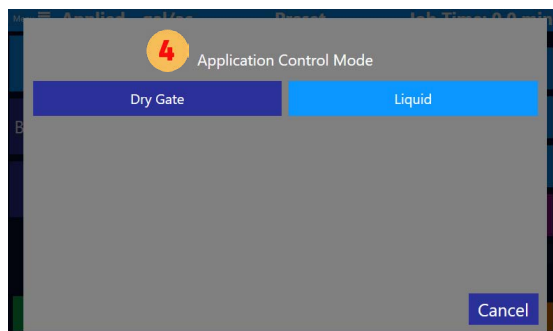

The connected controller, controller's state, Falcon dispersal sensor, and flow control dispersal are displayed.

NOTE

The buttons to reset 'Total Liquid Area', 'Total Liquid Volume', and 'Total Liquid Time' are located in the lower part of the screen seen in Step 11.

- 12** Tap 'Devices'
- 13** Tap 'Liquid Accessories'
- 14** If auto dispersal, tap 'Primary Boom Relay'
- 15** Select flow input requirements
- 16** Tap toggle button to set pressure transducer on or off
- 17** Tap 'Liquid Controller'
- 18** Tap buttons on the screen to set desired preferences
- 19** Tap 'Liquid Advanced'
- 20** Tap the buttons on the screen to set desired preferences.

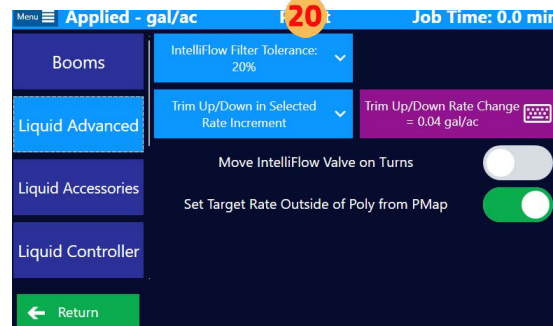
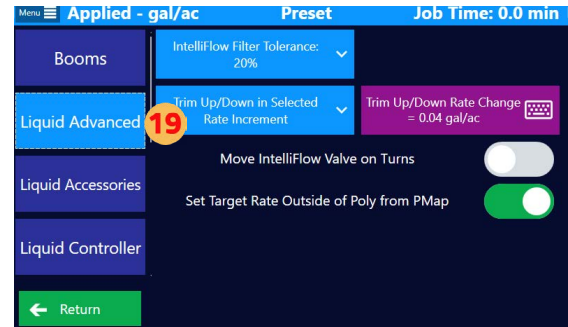
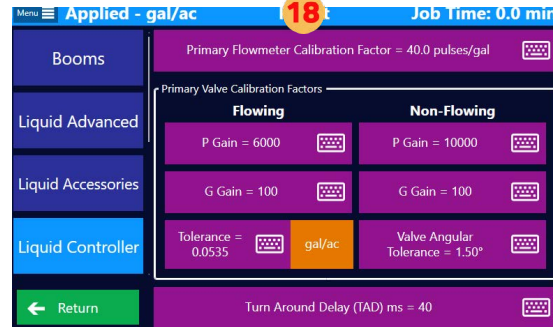
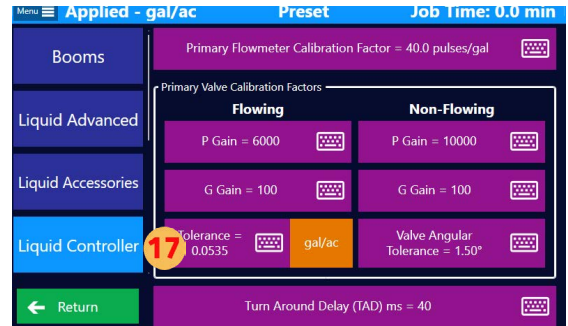
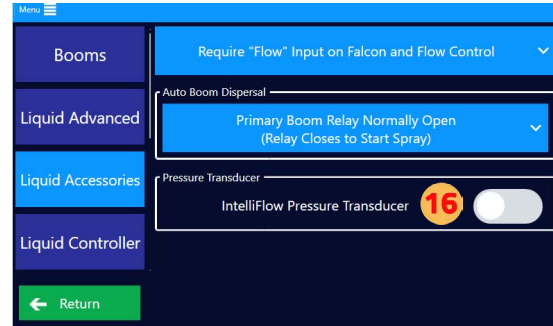
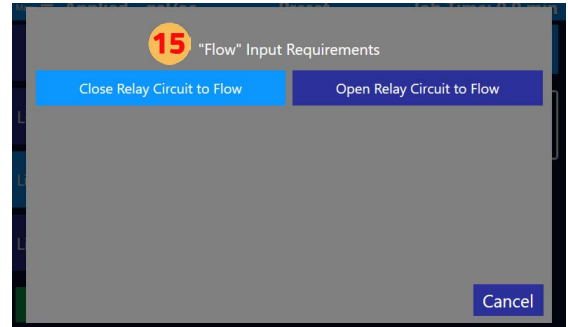
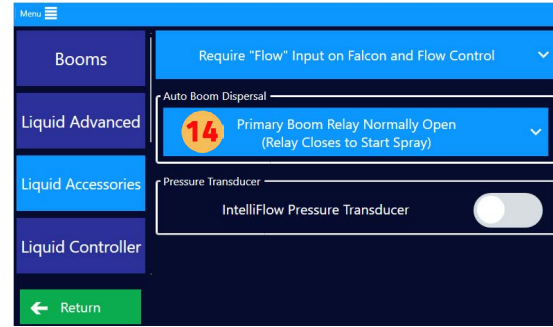
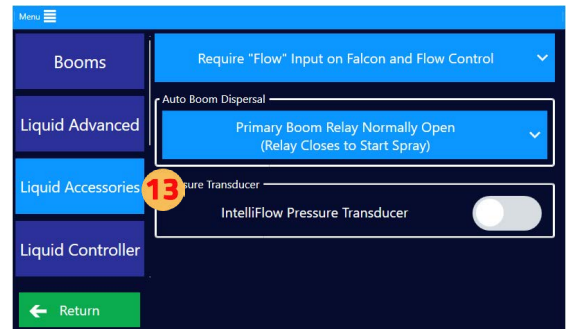

Test Flow Control for Liquid

- 1 Tap the 'Diagnostics'
- 2 Scroll down to 'Flow Diagnostics.' Then, tap 'Flow Diagnostics'
- 3 The flow status information will appear on the screen.
- 4 Tap 'Start Test Valve Movement' to run valve test.
- 5 Tap 'Move' button to set movement amount
- 6 Tap 'Open Valve per Time' to open valve by set amount
- 7 Tap 'Close Valve per Time' to close valve by set amount
- 8 Tap 'Full Open' to fully open valve
- 9 Tap 'Full Close' to fully close valve
- 10 Tap 'Go To Encoder Value' to set encoder value
- 11 Enter desired encoder value. Then, tap 'Ok.'

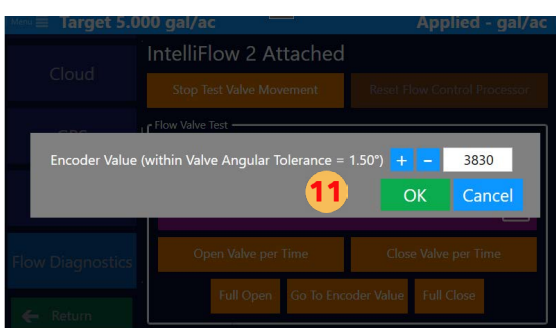
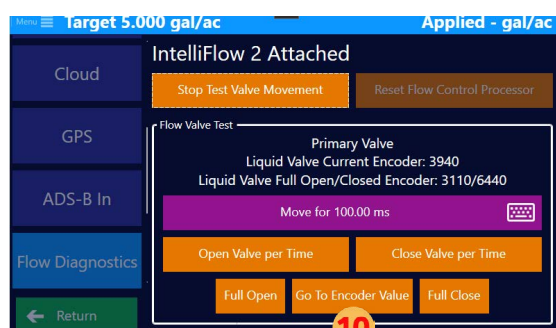
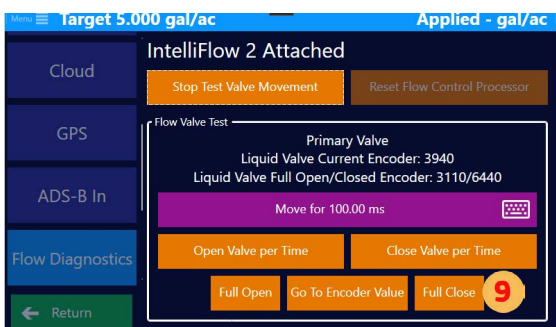
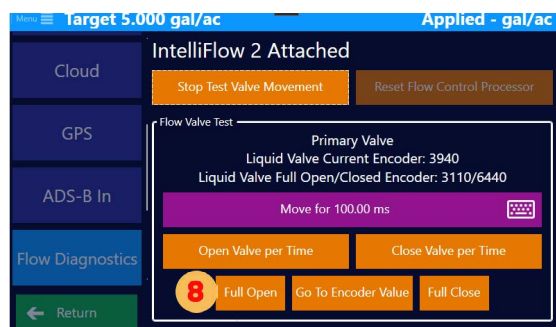
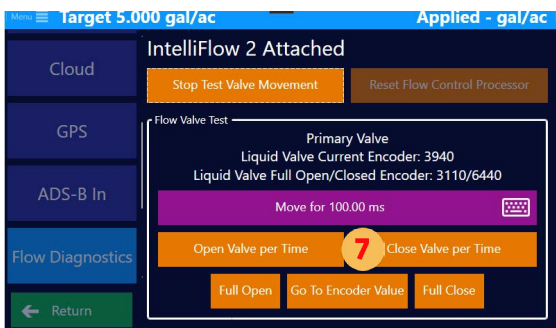
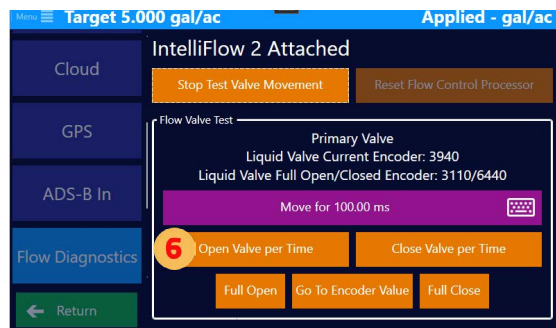
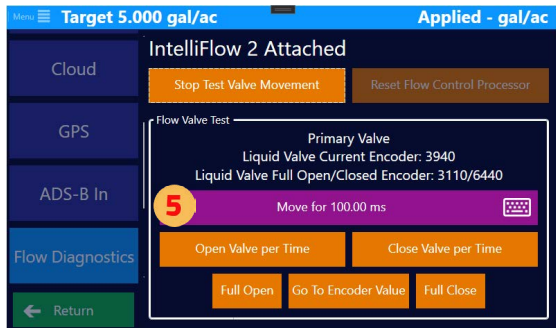
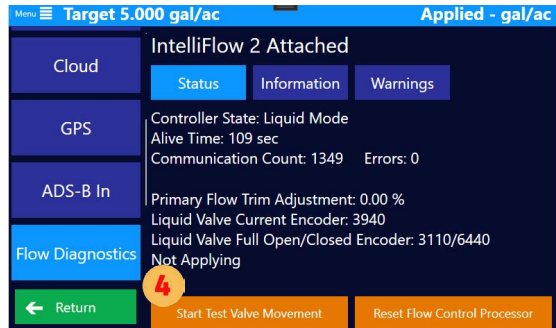
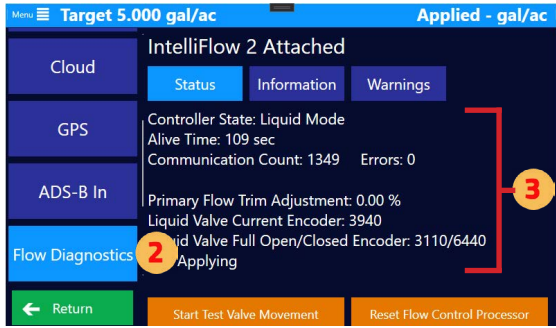

12 The valve will go to value within tolerance and the flow diagnostics screen appears. Tap 'Stop Test Valve Movement' button to exit test menu.

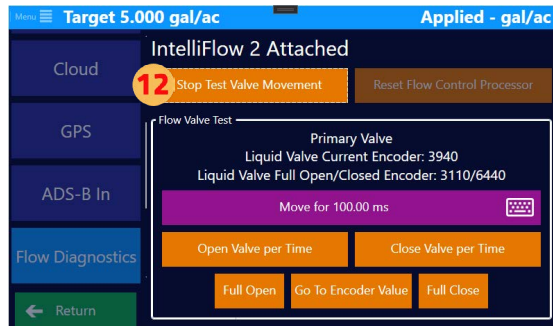

13 Tap 'Reset Flow Control Processor' to reset flow controller

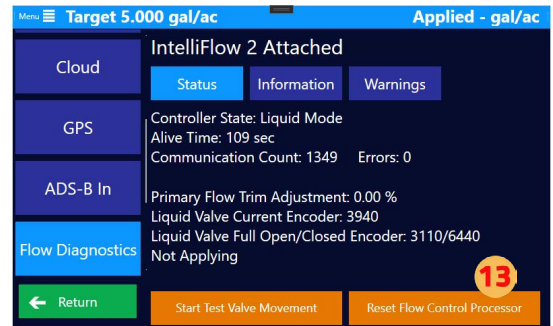

14 The flow status information will appear on the screen. Tap 'Information.' The flow controller information is displayed.

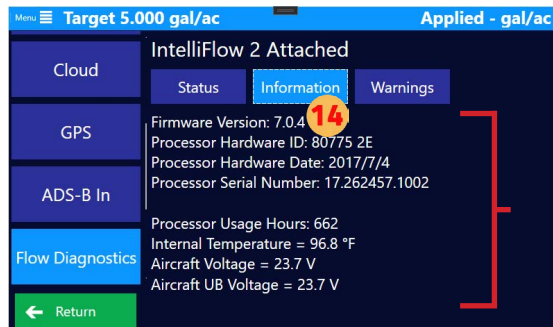

15 Tap 'Warnings' to display flow warnings.

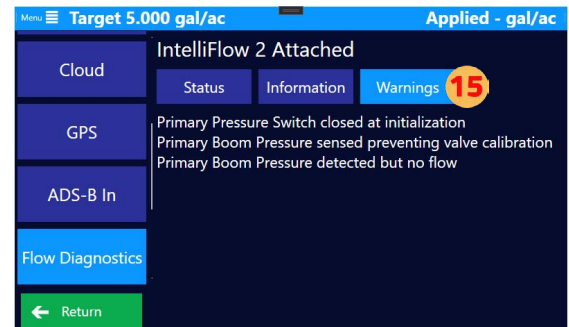

CHAPTER 3: BASIC TASKS

This chapter overviews aerial guidance terms, Falcon swath pattern selections, and basic task instructions.

WHAT'S IN THIS CHAPTER!

- 3.1 Aerial Guidance Terms
- 3.2 Available Pattern Types
- 3.3 Basic Tasks
- 3.4 Polygons
- 3.5 Basic Hotkey Tasks

3.1 AERIAL GUIDANCE TERMS

Before using Falcon/Falcon Pro, make sure you have a clear understanding of the aerial guidance terms used within Falcon/Falcon Pro and this user guide, and the automatic guidance features Falcon/Falcon Pro provides. These are covered in the first two chapters of this manual. This chapter provides basic information on how to start using Falcon/Falcon Pro to perform common tasks such as setting up a job, and logging data.

Term	Definition
Auto Dispersal	This is a feature of the Falcon Pro and available as an unlock to the Falcon. When a polygon or PMAP is loaded, this setting is turned on, and the application is set to constant rate poly or variable rate, the Falcon provides an output that can control an external device such as a fan brake that automatically starts and stops application when entering and exiting the polygon or PMAP area.
Crosstrack	The perpendicular distance between you and your target swath.
Heading Angle	The 'heading error'; the angular difference between your current heading and the heading of the target swath line in the direction of travel. When the heading angle is zero, you are on or parallel to the target swath (the cross-track will also be zero if you are on the target swath).
Increment/Decrement	Increment (known as 'Advance' in previous Satloc systems) advances to the next prescribed pass in a pattern and Decrement moves to the previous prescribed pass in a pattern. These functions are available through Falcon inputs (wired into the stick) or buttons on the Falcon Display. There is a Hotkey that will swap the function of increment and decrement for the stick inputs only when a pilot wants to reverse the function based on the current pattern direction. Such a reversal will automatically be cancelled when the user restarts or loads the same or different job.
Job	In the Falcon, a Job is the container for all the data associated with an application. All the applied paint and associated data, all patterns, all swathing, all polygons and PMAP (if applicable) are all contained within a job. New jobs can be created in real-time or jobs with pre-defined polygons and patterns can be imported. During application all associated data is automatically saved to the job. When returning to complete the application, simply open the job or return to a mark created during that job and all the associated data is automatically loaded and applied. Since jobs can contain multiple application patterns, returning to a particular pattern within a job can be through returning to the mark applied during that pattern, or selecting one of the patterns applied during the job through the hotkey: Logged Pattern.
Log	A set of position-specific data that always includes exact positioning and rate of spray application, precise time and date record, flight speed, altitude, patterns flown, and GPS position quality. Falcon/Falcon Pro logs this data while you are at or above a preset airspeed (default or user-set). Logs are contained within Jobs and exported (by default) as one Log file for review after flight.
Mark	A point to which you want to return, such as a last sprayed point. When you create a mark, Falcon/Falcon Pro saves: the swath number, pattern, A B line, direction, Job, acreage, swath width, and spray information.
Mark '0'	Mark '0' is the last time you stopped applying. In the system, it is shown as 'M0'.
Pattern	The order (the sequence) in which, on demand, Falcon/Falcon Pro guides you to the swaths that make up the area to be sprayed. Guidance comprises heading and cross-track as well as a visual display of your aircraft (in its current position) and your target (start of swath). The swath array to which Falcon/Falcon Pro applies the pattern's sequence is generated by either the auto-application of an array to a polygon or the creation of an A B line.

Term	Definition
Polygon	Saved with 'boundary-defined' jobs, polygons are the shapes of a field (or other area, such as a forest plot) that you define. You can create two types of polygons in Falcon/Falcon Pro—inclusion polygons (enclosed areas you spray) and exclusion polygons (enclosed areas you do not spray). Inclusion and exclusion polygons visually show you the borders of your spray/no-spray areas in the map.
Poly Pattern	<p>A pilot can analyze one polygon or more than one polygon at the same time. The Falcon/Falcon Pro automatically computes the A B line and required passes for all the polygon lines. Users can then select the most efficient or any other based on their application needs. Here are ways to view your Best A B line:</p> <ul style="list-style-type: none"> • Sort by Passes, Length, or Heading with Background Maps <ul style="list-style-type: none"> • Passes - View the fewest turns first • Length - View by increasing poly line length • Heading - Rotate around left or right to analyze with external factors, such as wind direction
Swath	A strip or row of a field that you fly.
Waypoint	A point that represents the GPS coordinates of a significant location you want to record (that is, save). You can create/save waypoints while flying or in a dedicated waypoints window.

3.2 AVAILABLE PATTERN TYPES

Falcon and Falcon Pro systems support nine pattern types (both open and closed), providing the flexibility to fly any field shape. Below are images and descriptions that describe available patterns in Falcon software and how to fly them.

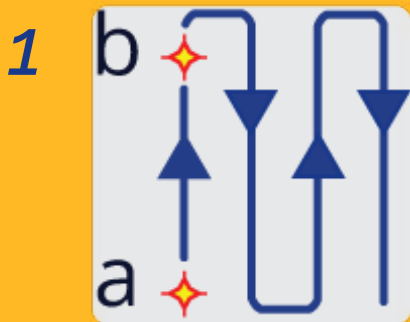

Back-to-Back

Fly consecutive swaths parallel to the A|B line.

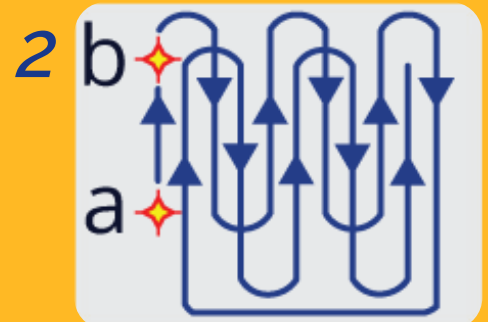

Back-to-Back Skip

Fly the odd-numbered swaths first, then the even-numbered swaths.

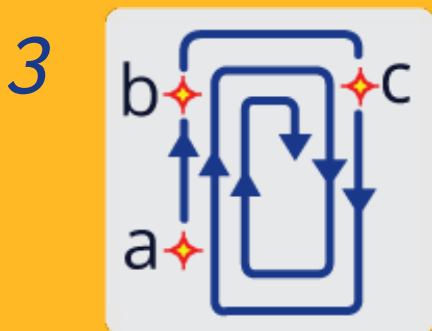

Squeeze

Fly loops of decreasing size from the outside of the field to the middle of the field. This pattern allows you to make wide turns at the beginning of a job when carrying a heavy load and narrower turns as your load becomes lighter.



Expand

Fly successive swaths outward from the center of the field. This pattern is useful for fields with a visible center line or a long, irregular shape.

5

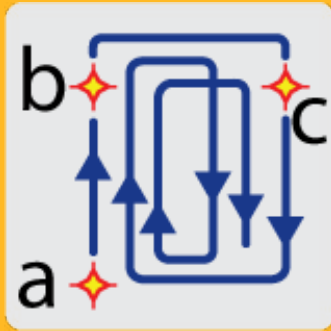

Racetrack

Fly each side of a field, then alternately work from swath #2 to the middle and from the middle toward the other end of the field. This pattern is useful for flying wide, smooth turns.

6

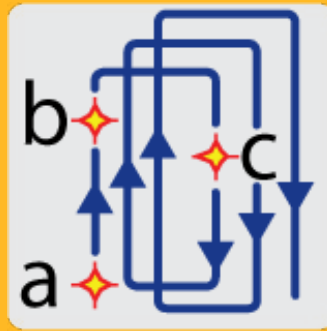

Quick Racetrack

Fly a pattern similar to the racetrack, but set your C point in the middle of the field.

7

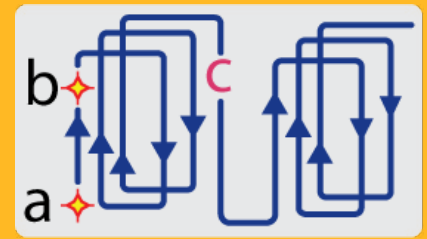

QuickTrack X

Fly a pattern similar to the quick racetrack. You specify the 'C' point for QuickTrack X patterns by the number of swaths or the distance from A|B to the furthest swath in the pattern. After you have set the A and B points, fly the pattern like a quick racetrack: the second swath is in the middle of the field, the third is swath #2, and so forth.

8



Reverse Racetrack

Fly a pattern similar to the racetrack. This is called the "reverse" racetrack because you are flying in one direction, but swaths are incrementing in the opposite direction. In this pattern, you set your A|B line in the center of the field. This pattern is useful for flying circular fields or other fields where the center line is clearly visible.

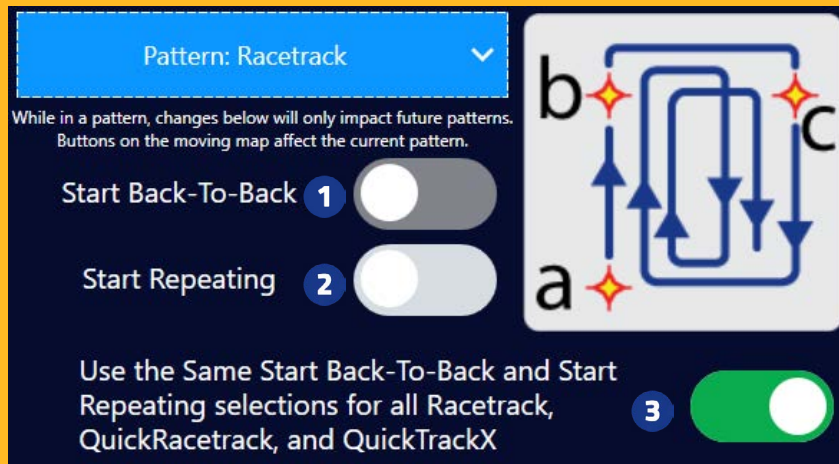

The following functions are only available for Racetrack, QuickRacetrack, and QuickTraxX.

1 Start Back-To-Back

Purpose: To allow any number of back-to-back passes at the beginning of a pattern. This is especially useful when using reduced swath width around sensitive areas. The Falcon manages each swath with its own width allowing, for instance, 4 passes at 50% boom and then continuing with a racetrack pattern at full boom width.

Instructions when feature is enabled:

- A. Set A|B Line: Begin by establishing an A|B line. This line serves as a reference or baseline for your pattern.
- B. Fly Back-To-Back passes
- C. When ready to switch to the next pattern type, click the button on the screen that says “Start Racetrack” or whatever pattern is coming. For Racetrack or Quick Racetrack, the Falcon will then guide to set the ‘C’ point. Continue flying the new pattern as usual.

2 Start Repeating

Purpose: To allow for the continuous repetition of a selected pattern across the entire field. Repeating patterns can be switched to finish back-to-back by user command.

When feature is disabled: After the last swath of the pattern, then pattern will switch to back-to-back for the completion of the field.

When feature is enabled: After the last swath of the pattern, the same pattern will commence again. Fly copies of the pattern as many times as desired. If back-to-back is needed to complete the field, click the button on the moving map that says “End Rpt.” A confirmation to end the repeat after completing this pattern group will appear. Finish the current pattern, then the pattern will switch to back-to-back.

3 Use the Same

Purpose: To provide consistency in settings across different pattern types or allow for individual customization.

When feature is disabled: If you prefer different settings for each pattern type, adjust them individually as needed.



When feature is enabled: If you want the same settings (like Start Back-To-Back and Start Repeating) applied across all three pattern types, select the “Use the Same” option.



3.3 BASIC TASKS

Usage of the Falcon is greatly dependent on the pilot's preferences and often by the application type. These sub-sections explain general actions for application basic tasks.

New Jobs and Predefined Jobs

As explained in Section 1.2, everything in the Satloc Falcon is contained in a Job: application data, swathing, patterns, optional polygons, etc. Jobs start as blank canvases with no particular application type (dry or liquid), no swathing (current swath number and swath widths), etc. Once application begins, things begin to solidify in the Job. This will alert the pilot if they have switched flow types upon a Job reload or have a different swath width than was last used when returning to a mark.

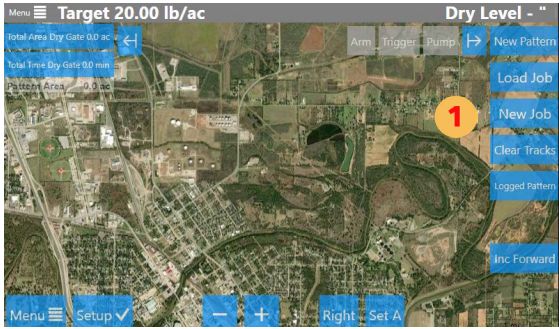
Action	Navigation Path
<p>Start a New Job from the Startup Menu</p> <p>Note: If the user creates a new job on the Falcon, a default job name is suggested with the Falcon's serial number, date of application, and daily job counter as the job name. The user could instead name the Job something else.</p>	 <ol style="list-style-type: none"> 1 Opens a menu to load an existing job. 2 Opens a menu to select a previous mark. 3 Returns to Mark '0', seen as MO in the system. (M0 is the last time you stopped applying.) 4 Opens a menu to create a new Job and name it. 5 Automatically creates a new Job with a default name based on the serial number, date, and daily job counter. 6 Opens a menu to import a Job from a USB.
<p>Start a New Job through Main Menu</p>	<p><i>Main Menu > Jobs > Job Selection > New</i></p> <ol style="list-style-type: none"> 1 Jobs 2 Job Selection 3 New 

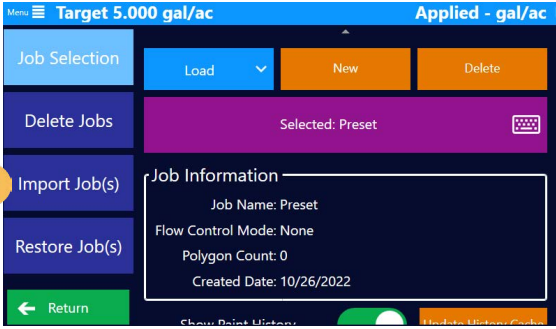
Action	Navigation Path
<p>Start a Job from a HotKey</p>	<p><i>Moving Map > New Job</i></p>  <p>1 New Job</p>
<p>Start a Pre-defined Job from Satloc Cloud</p>	<p>Predefined Jobs are those generated by MapStar or other programs that include polygons or prescription maps. These files (.job, .pmd, .pmh, etc.) can be uploaded to the Satloc Cloud and sent directly to the Falcon or imported on a Falcon directly through a thumb drive.</p> <p>Those sent through the Satloc Cloud simply appear on the Falcon as jobs ready to be loaded. No further action is required.</p>
<p>Start a Job from a Thumb Drive</p>	<p><i>Main Menu > Jobs > Import Job(s)</i></p> <p>1 Jobs 2 Import Job(s)</p>   <p>3 A Windows dialog box will appear. Navigate to your thumb drive, select the files, and click open. Start a predefined job by loading it.</p>

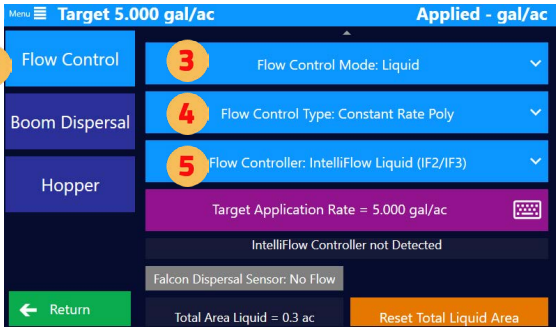

Application Settings for New Job

Before starting to apply, specific settings are required to be set.

Action	Navigation Path
Set Application Type	<p><i>Main Menu > Application > Flow Control</i></p> <p>1 Application 2 Flow Control 3 Select Flow Control Mode</p>  
	<p>4 Select Flow Control Type (See Note on side). If choosing a Flow Control Type other than 'None,' select Flow Control Type button and choose either Constant Rate or Constant Poly Rate. Both types expect a controller to provide this constant rate, and the Poly option will enable Lightbar triggering indication in the center circle per the Lightbar Setup.</p>
	<p>5 If choosing a Flow Control Type other than 'None,' select Flow Controller button and choose a controller. NOTE: If you have a controller for a particular type of application, that setup and use is covered in another section. However, an estimated flow rate is shown when there is no control type or controller. This rate is used while applying to estimate volume and pounds applied and related hopper status.</p>
	<p style="text-align: center;">Estimated Flow Rate = 5.000 gal/min</p>
	<div style="border: 1px solid black; padding: 10px; background-color: #f9a825; color: white;"> <p>NOTE</p> <p>The most basic type of application is Flow Control Type: None. In this type of application, the Falcon will simply record application areas ("paint") without any rates, and the pilot strictly controls the start and stop of application.</p> </div>

Pattern Settings for New Job

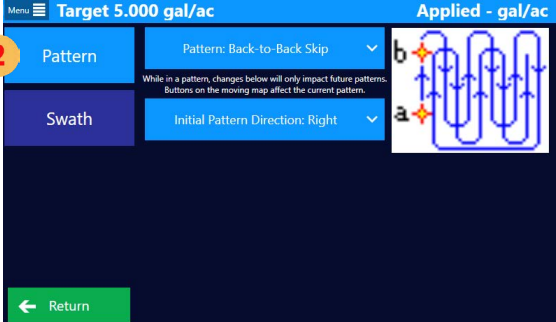
Action	Navigation Path
Start a New Pattern through HotKey	<p><i>Moving Map > New Pattern</i></p> 
	<p>1 New Pattern</p>
	<div style="border: 1px solid black; padding: 10px; background-color: #4a86e8; color: white;"> <p>TIP</p> <p>Section 3.2 describes available pattern types in the Falcon/Falcon Pro.</p> </div>

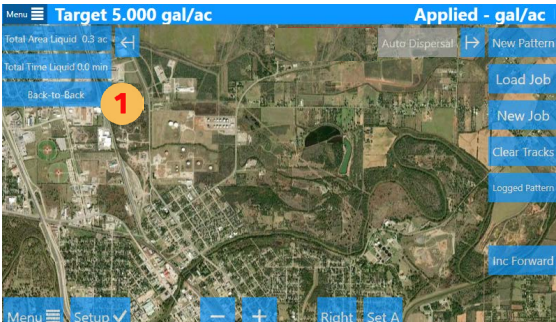

Action	Navigation Path
<p>Set Pattern through Main Menu</p>	<p><i>Main Menu > Pattern Swath > Pattern</i></p> <p>1 Pattern Swath Pattern</p>  
<p>Set Pattern through Setup Menu</p>	<p><i>Moving Map > Setup</i></p>  <p>1 Setup</p>
<p>Set Pattern through Left Display Pattern Button</p>	<p><i>Moving Map > Pattern</i></p>  <p>1 Pattern (The text on this button is the current, or next, pattern name.)</p> <div data-bbox="1146 1262 1511 1604" style="border: 1px solid #0070C0; border-radius: 10px; padding: 10px; background-color: #D9E1F2;"> <p>TIP</p> <p>To edit the Left Display Area, follow this path Main Menu > Display > Screen Displays. For more information, go to Section 2.5.</p> </div>

NOTE

The pattern selected will be retained and any new pattern will initialize to this selected pattern. Once a pattern has started, changes to the pattern will affect only the next new pattern; the current pattern will not change.

Swath Width for New Job

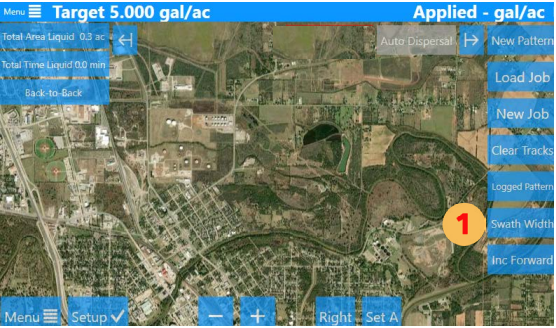
The Falcon retains a unique Swath Width per Application Type. For instance, dry and liquid modes can have different widths, and the pilot does not need to remember to update the swath width when switching application modes.

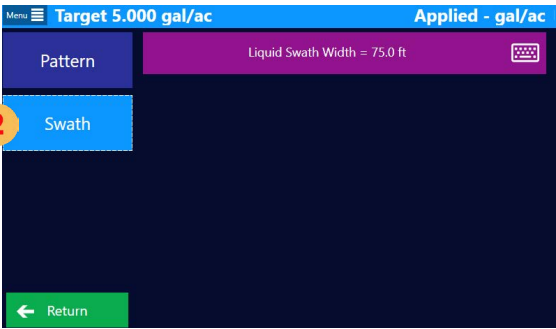
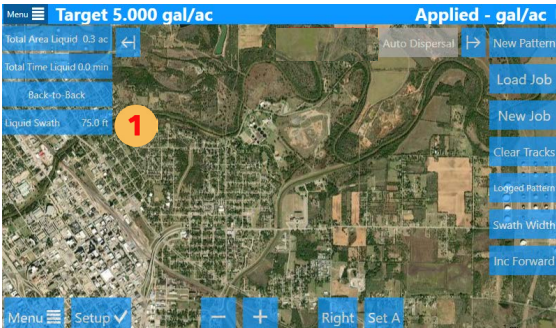
Action	Navigation Path
Set Swath Width through HotKey	<p><i>Moving Map > Swath Width</i></p>  <p>1 Swath Width</p> <div style="border: 1px solid orange; background-color: #f4a460; padding: 10px; margin-top: 10px;"> <p>NOTE</p> <p>Once a particular pass has been applied, that pass's Swath Width is set. Likewise, any passes between that pass and the A B line will also be set. Only future, unapplied passes can have their Swath Width changed.</p> </div>
Set Swath Width through Main Menu	<p><i>Main Menu > Swath Width</i></p> <p>1 Pattern Swath 2 Swath</p>  
Set Swath Width through Left Display Pattern Button	<p><i>Moving Map > Swath Width</i></p>  <p>1 Pattern</p>



NOTE

The swath width can also be set through a selected TopHat or Encoder Input. Also, it can be set by following this path Main Menu > Application > Dispersal (dispersal button will depend upon application type).

Starting Application & Pattern

Fly the initial A|B pass selecting Increment on the stick input or on the screen to set the A and B marks. Depending on the chosen Pattern and if Pre-Pattern Back-to-Back is enabled, the C mark may be required next.

Applying product (“Painting”) will display on the screen, and the Lightbar will indicate with Blue LEDs in the bottom left corners. Stopping application will drop a Mark 0 indicator.

Once product is applied in this Pattern, the Pattern is added to the Job. This is important to remember as it allows the user to return to any pattern within a Job regardless of saved Marks.

Starting a New Pattern

There are multiple reasons to start a new Pattern within a Job. It could be a different field, the wind changed, the shape of the field, etc. While a job is loaded, click the HotKey ‘New Pattern.’ The selected Pattern will initialize and be ready for a new A|B line.

Note: The previous Pattern and its Swathing information and this new Pattern and its Swathing information can be reloaded (while the current job is loaded) by clicking the HotKey ‘Logged Pattern.’



TIP

To edit the HotKeys, follow this path Main Menu > Display > HotKeys. For more information, go to Section 2.5. More information about HotKeys is included later in this chapter.

Logged Patterns

All patterns and swathing information is contained within a job. This means that simply by loading a job, the user has access to all defined patterns. The Logged Pattern Hotkey will show a list of all patterns flown in a job giving Pattern Type, Swath #, and Swath Heading to allow ease of selection. Clicking one of these logged patterns restores the Falcon to that pattern similar to returning to a Mark.

The benefit of Logged Pattern is that the pilot doesn’t have to drop a mark for each pattern in a job and remember which mark to return to later; simply loading the same job and clicking logged pattern allows returning to any pattern without any marks.

Note: Setting and Returning to a Mark still functions as previous Satloc GPS systems (with some improvements mentioned in the Marks section).

Make sure you’ve set ‘Logged Pattern’ as a hotkey. Then use the following path: *Logged Pattern* > (Select a Log Pattern).

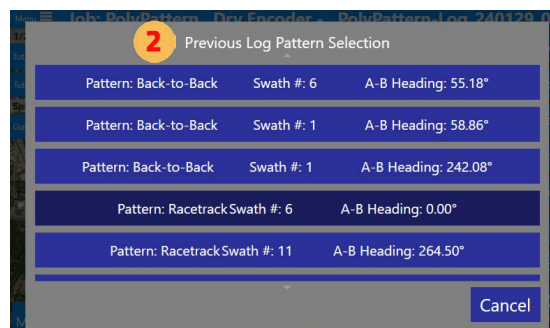
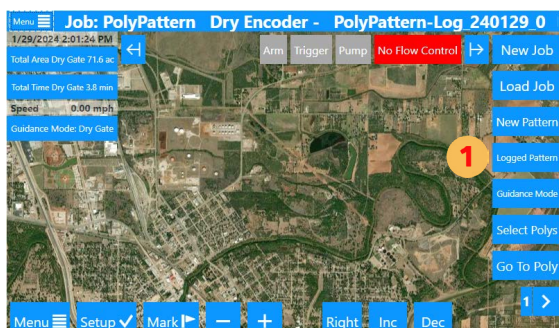

Marks

A user can save a mark by clicking the  button on the screen.

The user can type up to 4 digits as an identifier for a mark (1 – 9999). If that mark was already saved, the mark information is presented to give the user an option to overwrite or pick a different mark.

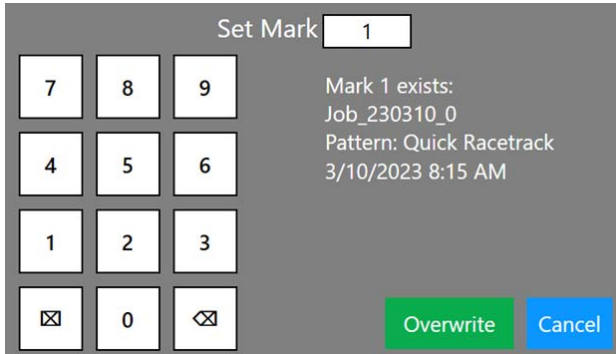

Set Mark

7	8	9
4	5	6
1	2	3
⊗	0	⊗

Mark 1 exists:
Job_230310_0
Pattern: Quick Racetrack
3/10/2023 8:15 AM

Marks contain information on the Job and the specific pattern/swathing inside that Job. Clicking to return to a Mark will load that Job and all its paint and restore the particular pattern and swathing information.

Mark 0 is set every time a pilot stops applying (painting). The user sets the remaining marks (1 – 9999) at will. Returning to a Mark can be done through a HotKey, the Setup Menu, or the Startup Menu. If the Job associated with a saved Mark has been deleted, a notice will be shown, and the current Job will remain loaded.

3.4 POLYGONS

Some jobs created outside the Falcon may contain polygons. When loaded, these polygons will automatically be enabled and displayed. The Lightbar will indicate edge triggering when the Application Flow Type is set to Constant Rate Poly or Variable Rate Poly. Additionally, the Auto Dispersal output can automatically control dispersal for Falcon Pro or a Falcon with Auto Dispersal Unlock.

Users can elect to select only specific polygons. This selection can be made through navigating to *Menu > Jobs > Polygon Selection* or a HotKey.

There are two sets of timing for Polygon triggering:

1. On the Lightbar Settings, the Center section for visual edge Trigger can be set for Time or Distance.
2. Auto Dispersal Enabled and the Auto Dispersal Timing are set per application type (this can differ for Liquid, Dry, etc.). These are set by navigating to *Menu > Application* and then selecting the appropriate tab: Boom Dispersal, Gate Dispersal, etc.

Polygon Pattern Analysis

A pilot can analyze one polygon or more than one polygon at the same time. The Falcon/Falcon Pro automatically computes the A|B line and required passes for all the polygon lines. Users can then select the most efficient or any other based on their application needs. Here are ways to view your best A|B line:

Sort by Passes, Length, or Heading with Background Maps

- Passes - View the fewest passes first
- Length - View by increasing A|B poly line length
- Heading - Rotate around left or right to analyze with external factors, such as wind direction

Analyze One Poly

The image to the right shows a single poly. The purple line represents the poly line from which the A|B line has been derived. Notice the orange arrow points in the direction of the pattern. Falcon/Falcon Pro shows an initial result of most efficient at 20 passes. After that, it identifies the least efficient at the top as 33 passes.



Analyze ALL Polys in a Job

The image to the left shows all the polys in a job. The Falcon/Falcon Pro software can analyze all the polygons and then sort by least amount of passes and most passes based upon the data.

Sort by Heading

The image to the right shows the heading rotated to a less efficient direction. The A|B line is parallel to the inset purple line. The aircraft started back a few swaths to hit the extremity of the field.

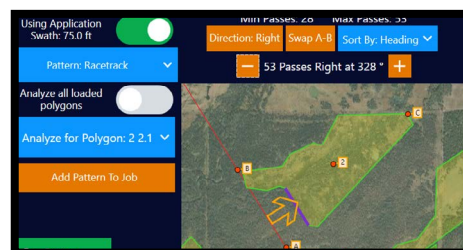

- 1 Tap 'Jobs'
- 2 Tap 'Load'
- 3 Select a Job
- 4 Tap 'Polygon Selection'
- 5 Select the Polygons you Want Visible
- 6 Tap 'Polygon Pattern'
- 7 Toggle On 'Using Application Swath' if you want to use Swath Width in Application or Toggle Off to Specify a Swath Width
- 8 Tap 'Pattern:'
- 9 Select a Pattern
- 10 Toggle On 'Analyze all loaded polygons' to Analyze all Polygons. Toggle Off to analyze a Specific Polygon.
- 11 Tap 'Run Analysis'

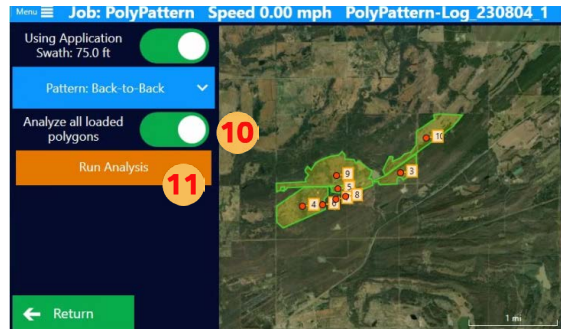
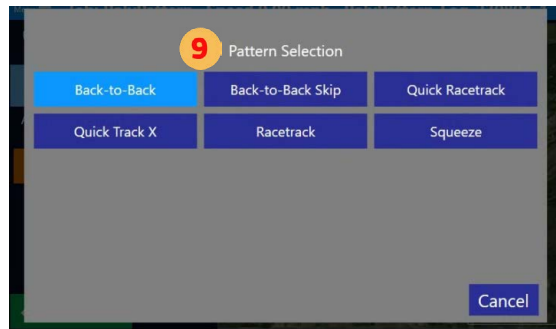
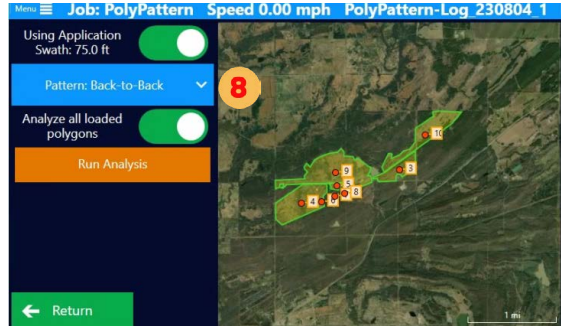
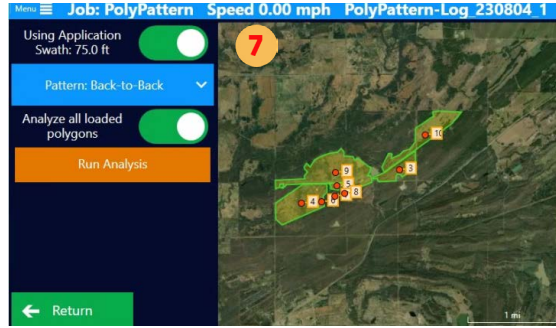
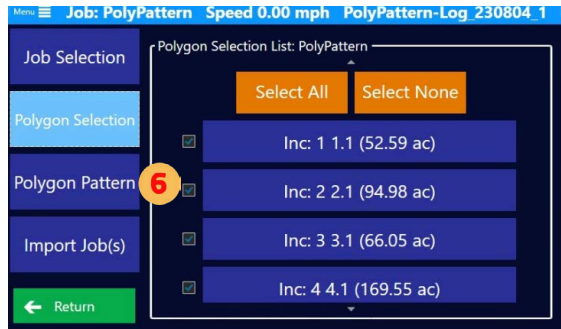
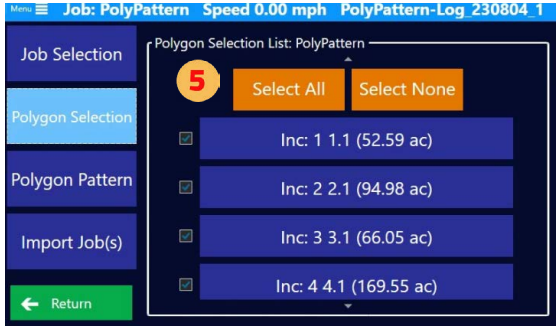
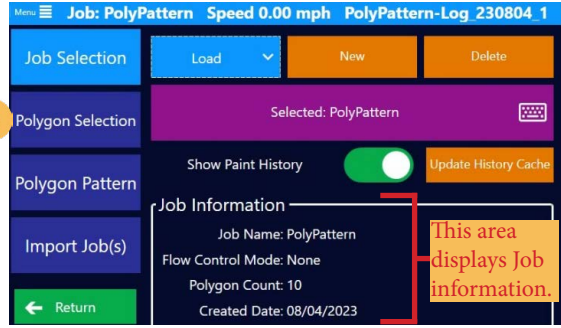
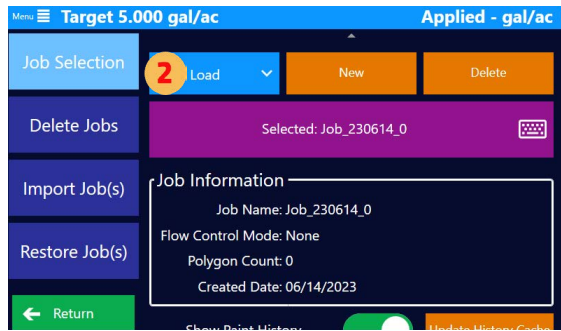

- 12** Polygon(s) are Analyzed
- 13** Tap 'Add Pattern to Job'
- 14** Tap 'OK.' Pattern is now added to Job.

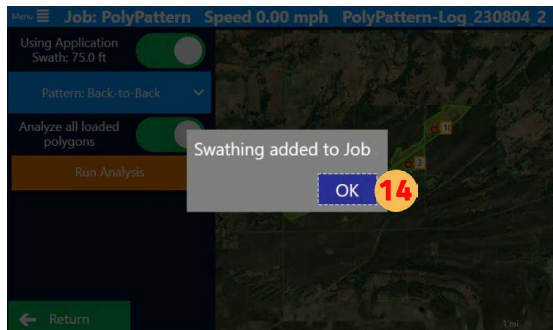
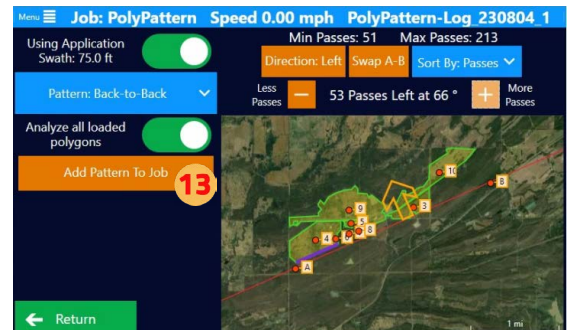
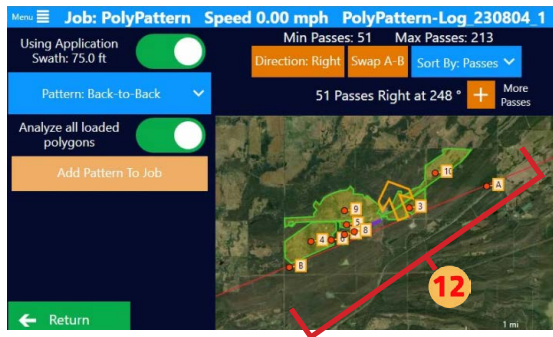

TIP

For a visual of how-to run polygon pattern analysis, visit Satloc's YouTube channel or click this [link](#) to take you directly to the video.



NOTE

There are three 'Sort By:' options - 1) Heading, 2) Length, and 3) Passes. This is chosen by the 'Sort By:' Button.

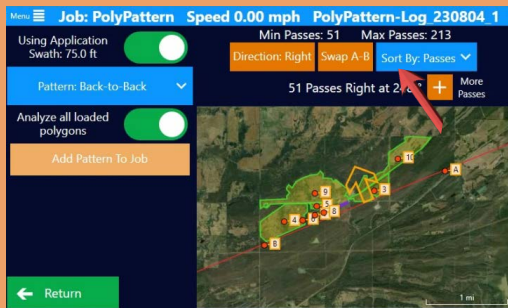

NOTE

Select 'Swap A-B' button to switch polygon start.

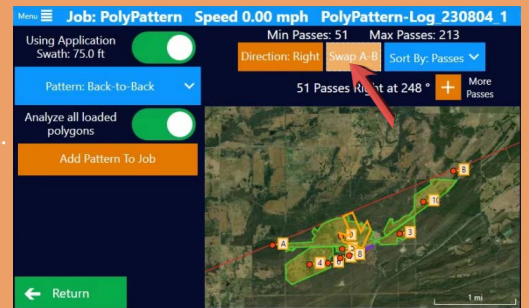

NOTE

The 'Direction' button switches the direction a pilot travels after the A|B Line.

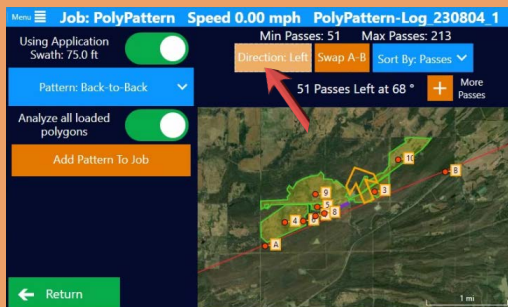

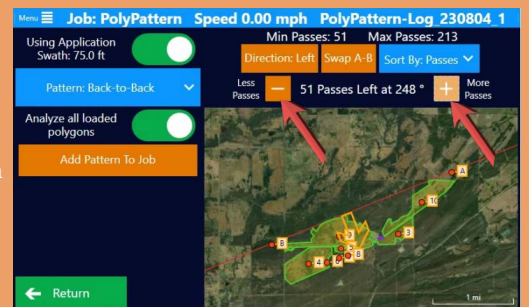

NOTE

The 'Less Passes' and 'More Passes' buttons change swath lines.

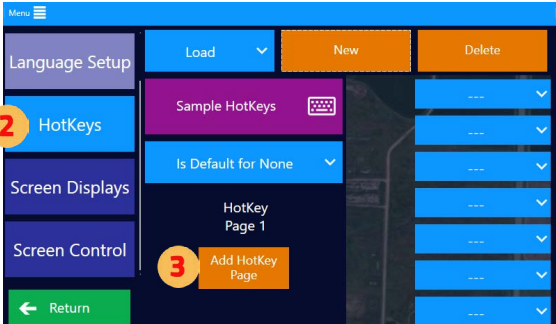
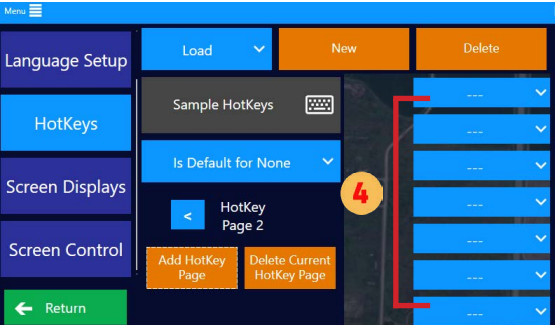

3.5 BASIC HOTKEY TASKS

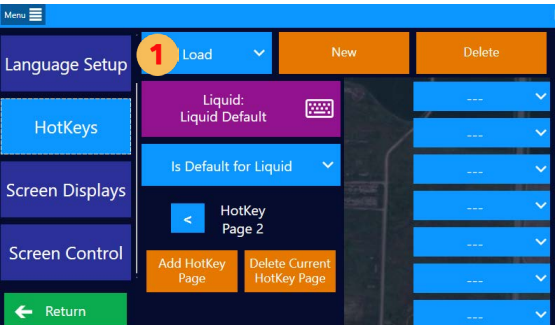
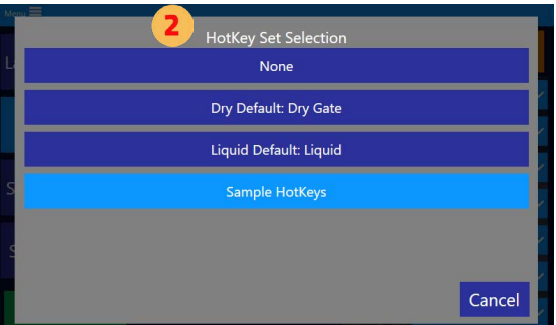
Action	Navigation Path
<p>Adding a HotKey Page</p>	<p><i>Main Menu > Display > HotKeys > Add HotKey Page</i></p> <ol style="list-style-type: none"> 1 Display 2 HotKeys 3 Add HotKey Page 4 Select a HotKey Slot on Dropdown Menu 5 Select one of the four (sometimes there are five or more, depending upon unlocks) main tabs at the top of the HotKey Selection screen and then choose an option for the slot.    
<p>Load a HotKey Set</p>	<p><i>Main Menu > Display > HotKeys > Load</i></p> <ol style="list-style-type: none"> 1 Load 2 Select a HotKey Set  

CHAPTER 4: ADVANCED SETUP

This chapter goes over setups that are typically not used a lot by aerial applicators.

WHAT'S IN THIS CHAPTER!

- 4.1 Boom Valves Setup
- 4.2 Transland Electric Gate Box Initial Setup
- 4.3 Levels Setup for Electric Gate
- 4.4 Single Profile Setup for Electric Gate
- 4.5 Hydraulic Gate Box Initial Setup
- 4.6 Levels Setup for Hydraulic Gate
- 4.7 Single Profile for Hydraulic Gate

4.1 BOOM VALVES SETUP

Setting Up Valve Control without Wizard

- 1 Tap 'Devices'
- 2 Tap 'Booms'
- 3 Tap the 'New'
- 4 Enter Boom Name. Then, tap 'Ok.'
- 5 Tap 'Boom Control'
- 6 Select the Type of Boom Control. A user must have 'Partial Boom' option enabled under *Main Menu > Advanced > Unlocks > Boom Control*.
- If selecting 'Boom Valves' option, complete the following steps.**
- 7 Tap 'Boom Valves'
- 8 Tap 'Boom Valves' (that is followed by a number)
- 9 Select the number of boom valves present on aircraft
- 10 Press on the valve number to select that valve and set its properties

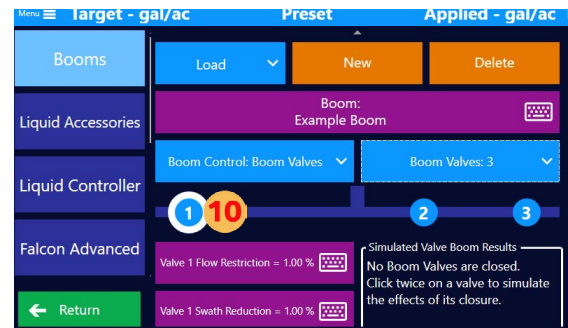
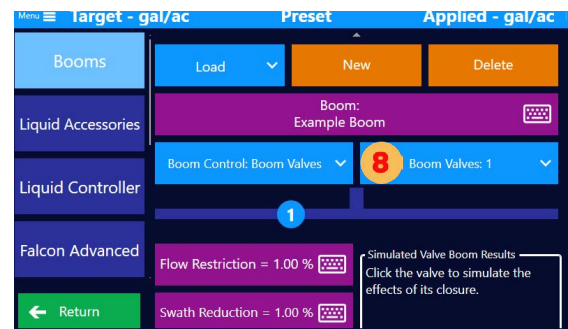
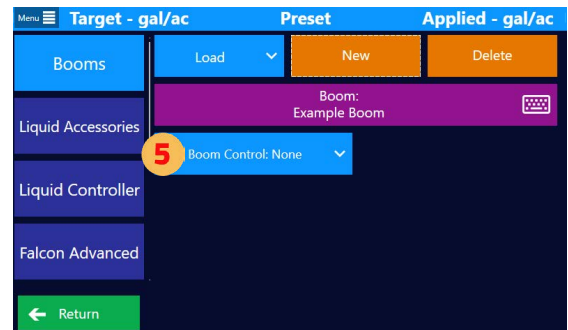
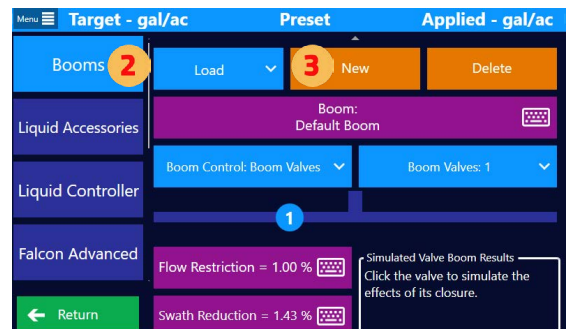
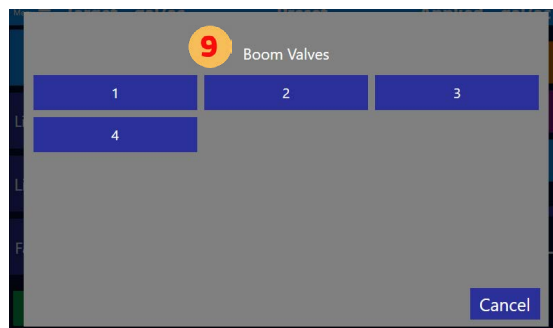
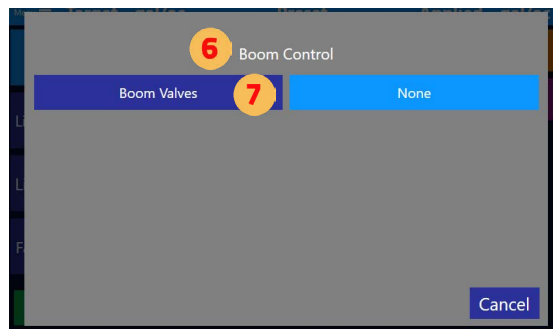
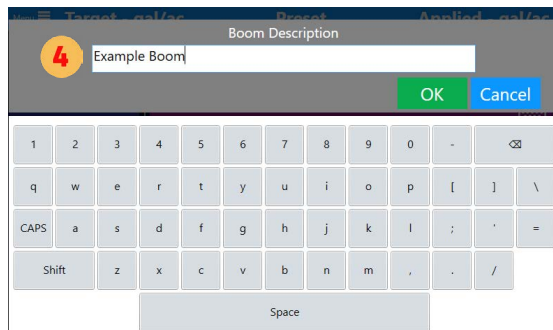

TIP

There is a Valve Control Setup Wizard.

- 11 Tap 'Valve Cut Off' to select which way the valve cuts off
- 12 Tap 'Flow Restriction'
- 13 Set flow restriction percentage. Then, tap 'OK.'
- 14 Tap 'Swath Reduction'
- 15 Set swath reduction percentage. Then, tap 'OK.'
- 16 Tap on a valve to simulate that valve closing. This does not close the actual valve, this is just to show the calculated changes that will happen when a valve does close.
- 17 Press the again to simulate that valve is open.

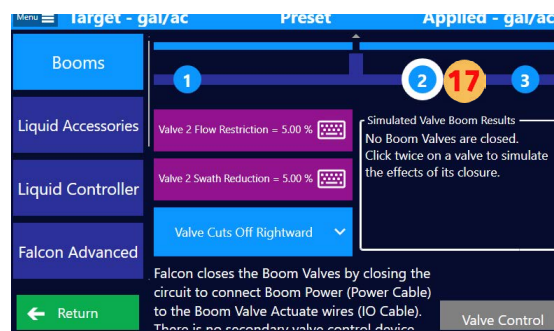
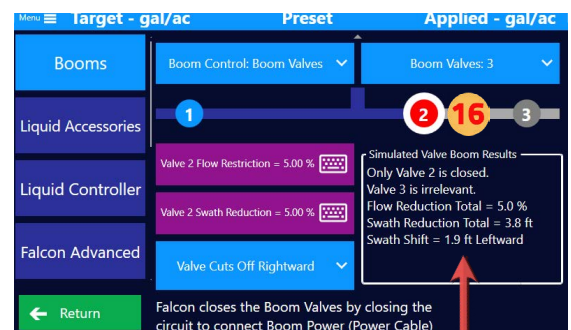
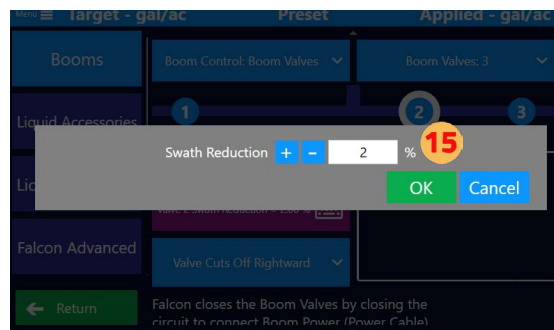
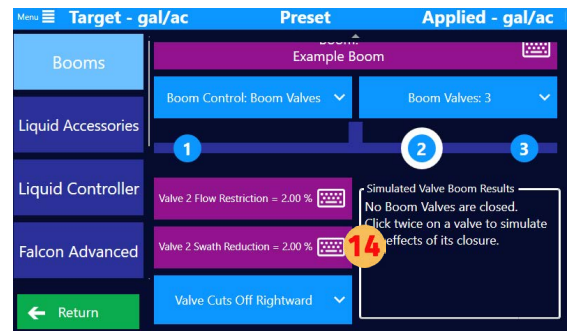
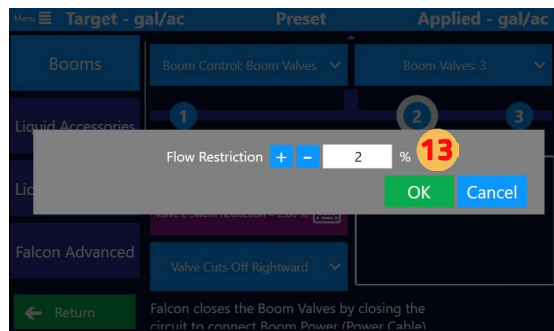
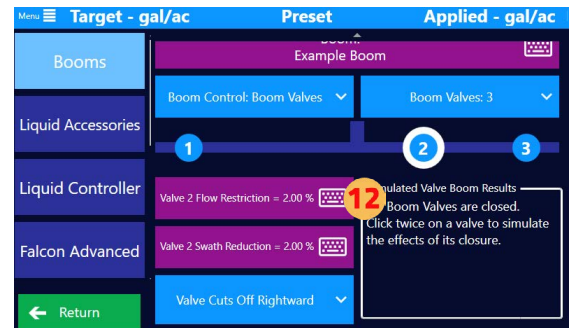
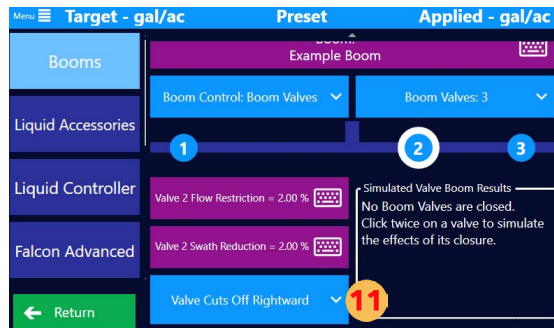

When a valve is closed, calculated results will show under 'Simulated Valve Boom Results' and display the following:

1. Which valves are closed
2. Whether a valve is irrelevant due to another valve's closure
3. Flow Reduction Total – the percent amount the overall flow has been reduced
4. Swath Reduction Total – the amount the swath width has been reduced
5. Swath Shift – the distance the swath's center has shifted

NOTE

Valve control settings are displayed at the bottom of the screen. Scroll down to view the settings.

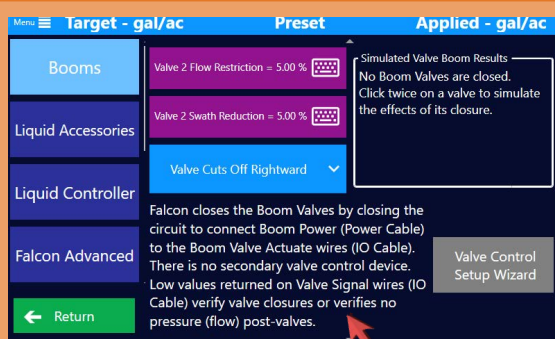



TIP

Suppose a valve's flow reduction or swath reduction is set to a value greater than or equal to an upstream valve. In that case, that value will be automatically increased, and a popup message will appear.

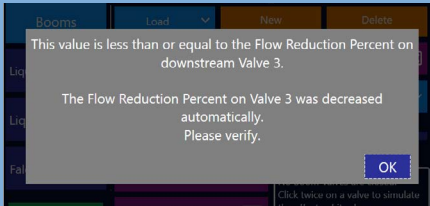

TIP

To move a valve to match the setup of the plane, select a valve in the middle, and the Valve Cuts Off option will appear. Press this option to specify if the valve cuts off leftward or rightward.

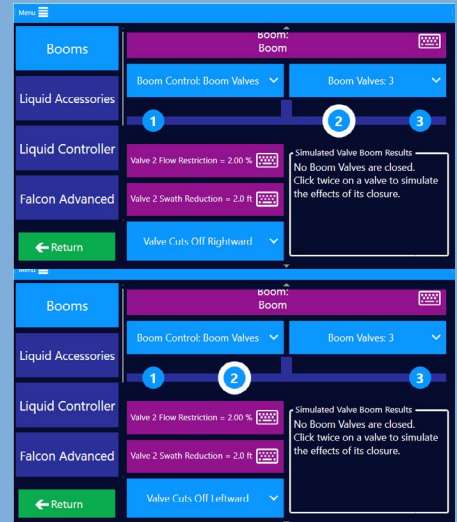

Setting Up Valve Control with Wizard

- 1 Tap 'Devices'
- 2 Tap 'Booms'
- 3 Scroll down to find setup wizard. Tap the 'Valve Control Setup Wizard.'
- 4 Follow the prompts to setup the system to control and receive proper signals.

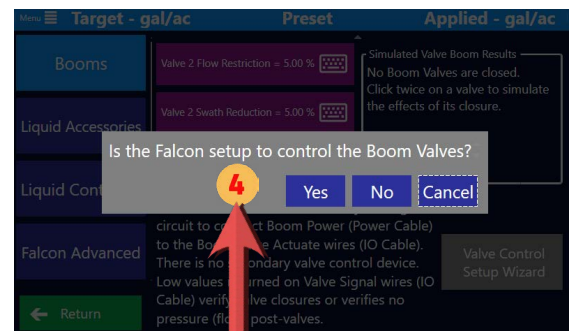
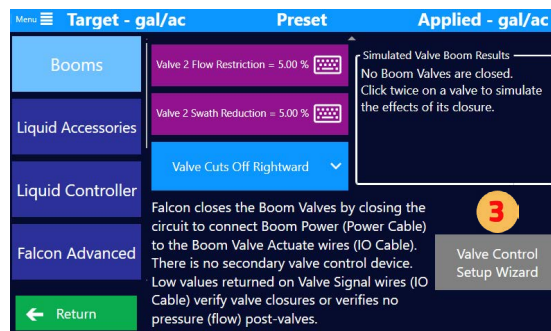
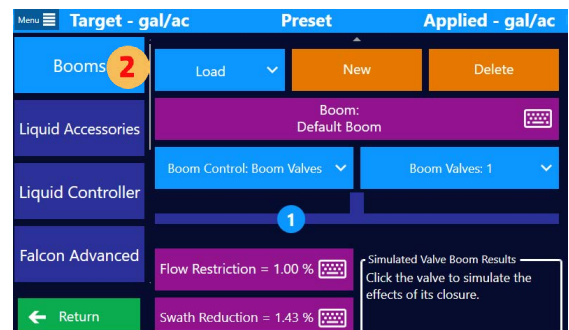

- Below are the popup prompts.
1. Is the Falcon set up to control the Boom Valves?
 2. Are there other switches, a controller, or handles to actuate the Boom Valves?
 3. Are there other switches, controller, or handles providing signals on the Pilot Boom Inputs on the IO Cable to indicate Valve actuations?
 4. On the signals from the other switches, controller, or handles, do HIGH values indicate the Valves are energized to CLOSE? (Yes=HIGH to close; No=LOW to close)
 5. Are there return signals from the Boom to verify the Boom Valves are closed?
 6. HIGH signals returned on the Falcon IO cable verify Valve closures or no flow post-Valves? (Yes=HIGH; No=LOW)

4.2 TRANSLAND ELECTRIC GATE BOX INITIAL SETUP

Selecting Flow Control Mode

Note: This section only applies to Falcon Pro systems.

- 1 Tap 'Advanced'
- 2 Tap 'Visibility'
- 3 Tap 'Flow Control'
- 4 Click the box for 'Controller Transland Electric Gate'
- 5 Go to Main Menu and tap 'Applications'
- 6 Tap 'Flow Control Mode'
- 7 Tap 'Dry Gate'
- 8 Tap 'Flow Control Type'
- 9 Tap 'Constant Rate'
- 10 Tap 'Flow Controller'
- 11 Tap 'Transland Electric Gate'

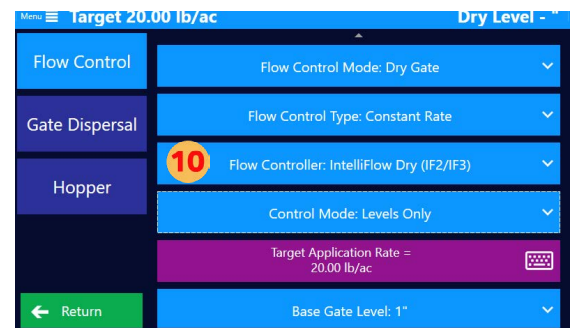
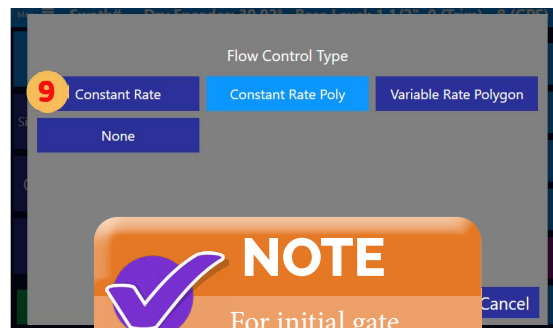
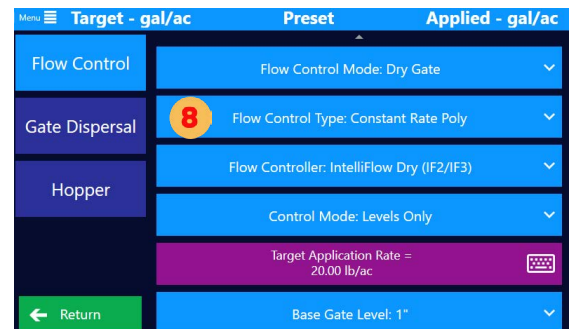
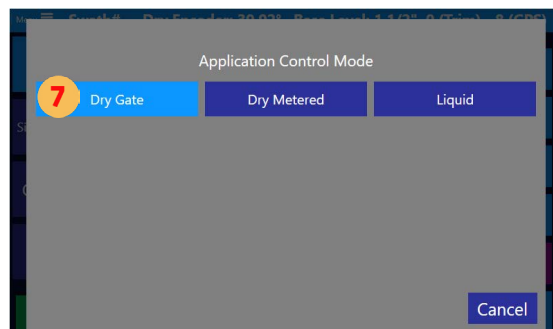
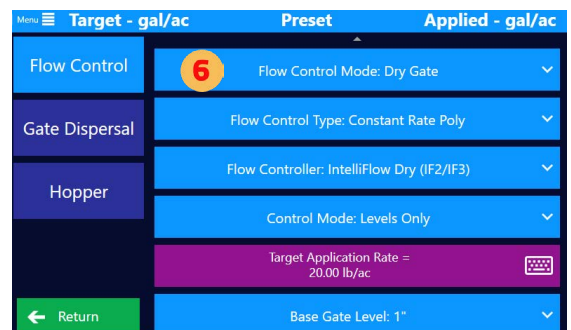
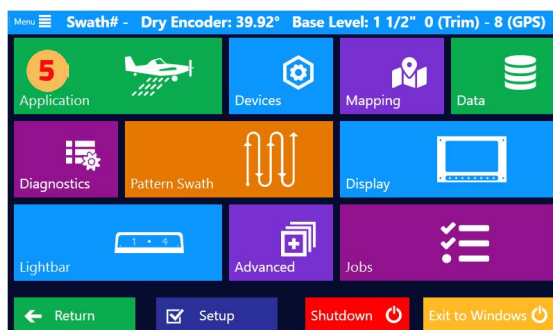
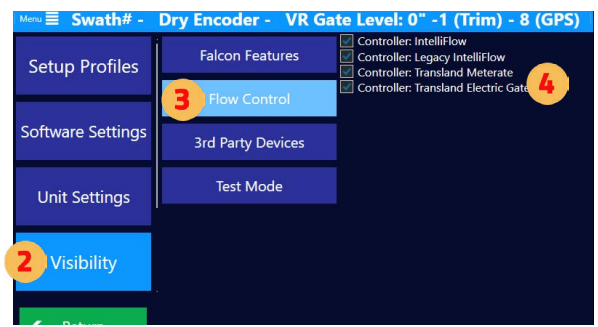

NOTE
 For initial gate setup, select "Constant Rate." If your jobs contain polys, after initial setup please change to "Constant Rate Poly."

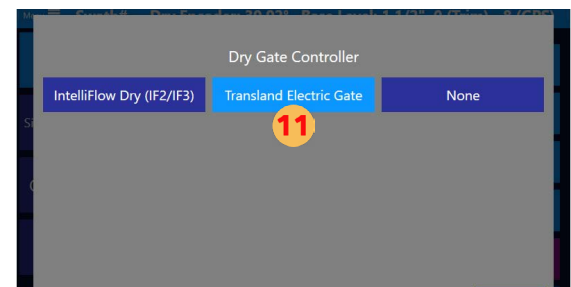

Dry Gate Input Setup

12 To verify all inputs and all top hat switches are mapped correctly, go to the Main Menu and tap 'Diagnostics.'

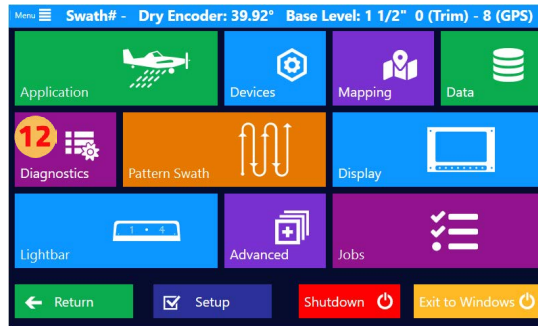

13 Tap 'IO Diagnostics' and verify all inputs and top hat selections are correct. Refer back to the top hat wiring during installation so that you'll know the mapping of the stick.

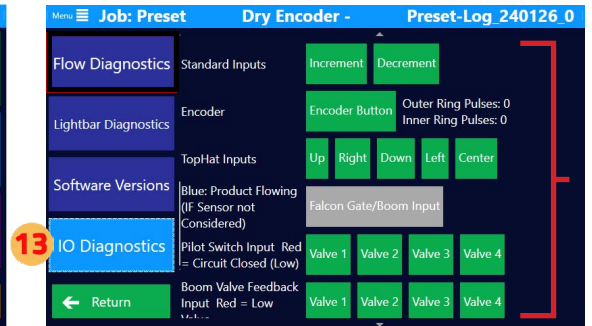

14 Go to Main Menu and tap 'Devices'



13 Tap 'Input'

14 There are two Standard Buttons - Set Choices for those buttons. **Note:** Increment - Means Advance

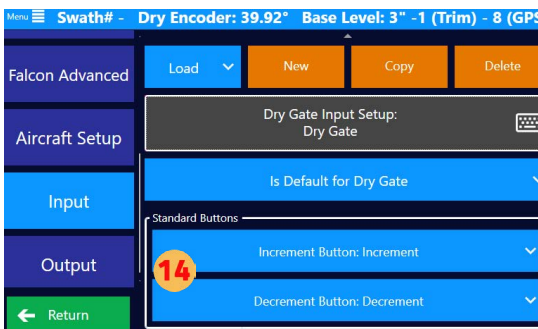

15 Set your choices for the Dry Gate Top Hat by tapping on the appropriate button. **Note:** Be sure that you did Steps 12 and 13 to verify the mapping.

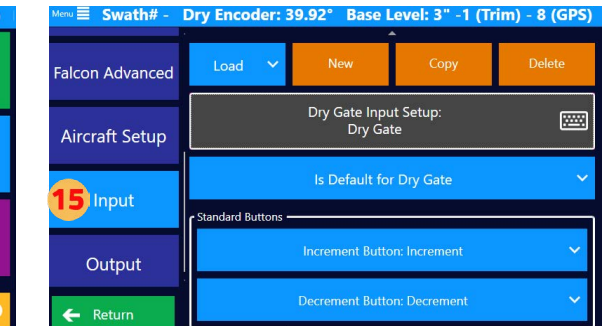

16 Select the desired function for the button.

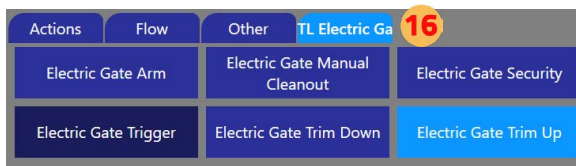

17 Set your Dry Gate COMs choices.

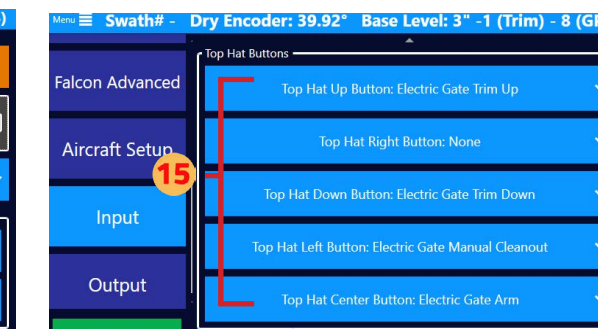

TIP

Satloc recommends setting up custom Display Settings (inputs, displays, hotkeys, & Lightbar) for all likely Guidance Modes (Liquid, Dry Gate, etc.) and a Display Setting for Ferrying. This information is covered in Chapter 2 of this manual.

Dry Gate Calibration

- 18 Go to Main Menu and tap 'Devices'
- 19 Tap 'Gate Closed Position'
- 20 Tap 'Latched'

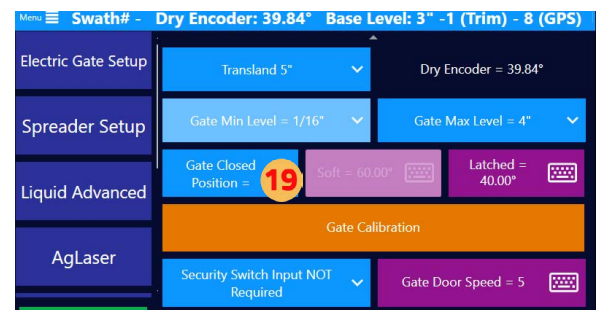

- 21 Ensure the gate door is physically latched shut.
- 22 Remove gear cover and small gear.
- 23 Loosen jettison so it can rotate freely on shaft.
- 24 Remove the aft gear (attached to actuator output)
- 25 Go to calibration page to be able to rotate motor shaft freely and read encoder.
- 26 Rotate actuator shaft either clockwise or counter clockwise, until reaching 40° position, shown on calibration page encoder value. The usable range of the encoder is 0°- 500°.
- 27 Reinstall aft gear at nearest tooth for final at 40° + or - 2°. Ensure gate is latched when installing gear. Re-install gear cover.
- 28 With gate latched and aft gear re-installed, read the encoder value and record it.
Note: The range for the Latched value is 20°-40°.



Warning: Keep hands clear of gear during operation.



NOTE

The usable range of the encoder is 0°- 500°.

- 29** You'll need to set the encoder value. Tap 'Latched.'
- 30** Enter encoder value. Then, tap 'OK.'
- 31** Reposition jettison arm and tighten it.
- 33** Tap 'Electric Gate Setup'
- 34** Tap 'Transland' Gate Type
- 35** Select 'Gate Type'
- 36** Tap 'Gate Min Level'
- 37** Set Minimum Operating Gate Levels
- 38** Tap 'Gate Max Level'
- 39** Set Maximum Operating Gate Levels
- 40** Tap 'Gate Closed Position'

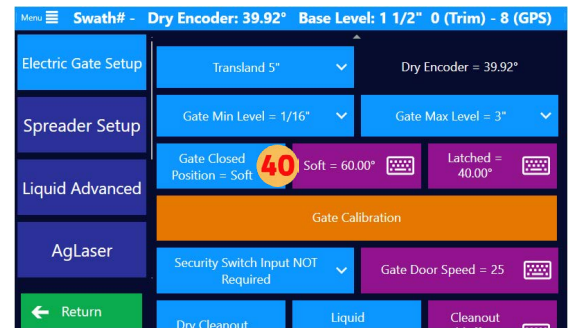
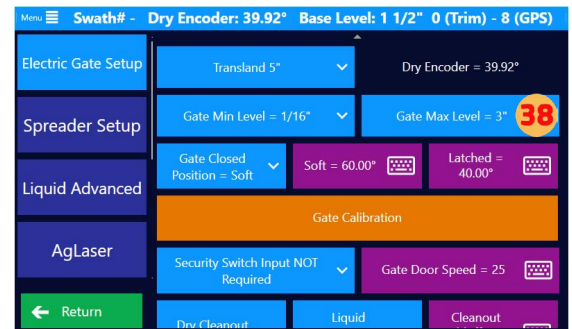
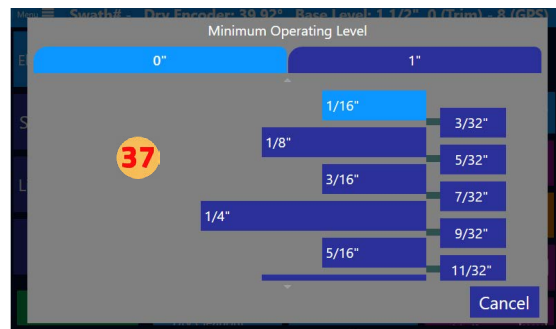
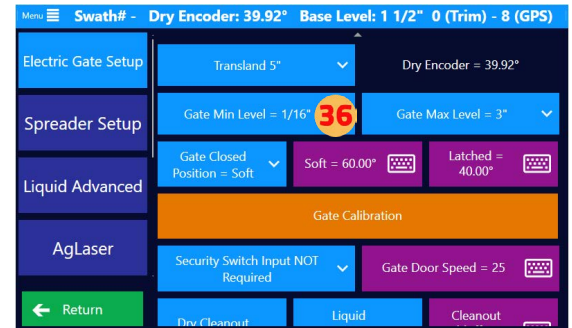
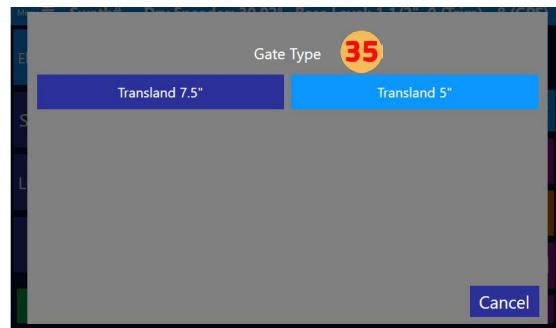
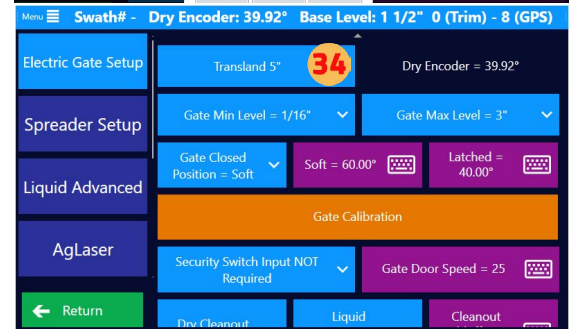
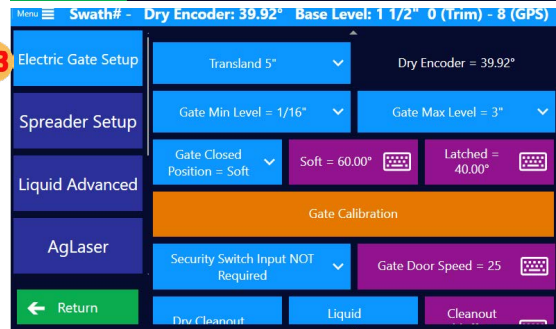
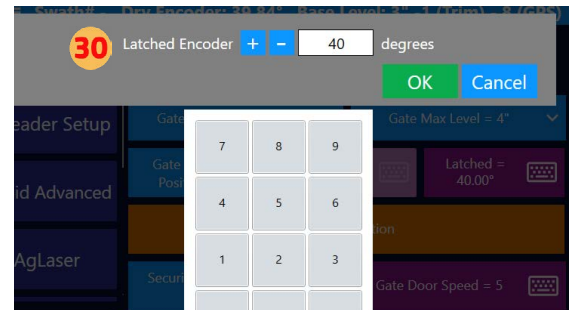
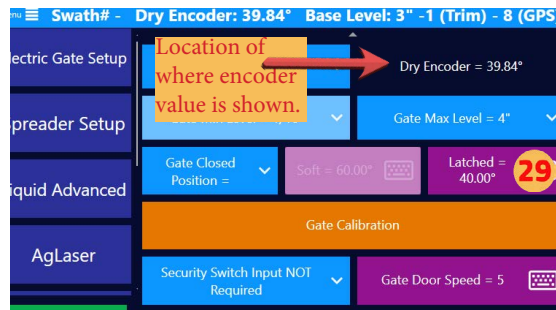

41 Select Gate Closed Position



42 Tap 'Gate Calibration'

NOTE: You will use Step 43 OR Step 44 to set gate openings.

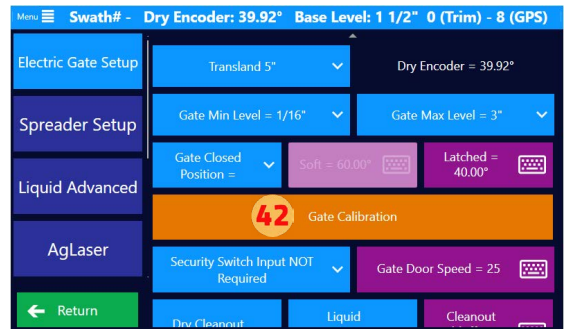

43 Tap 'Change' to Edit Calibration Numbers. With the gate unarmed, move gate to match opening and save encoder value at each step.

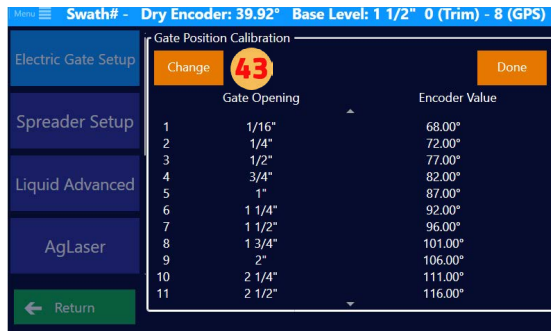

Remember: If you did Step 43, then skip Step 44. OR skip Step 43 if you choose to do Step 44.



44 To use the Arrow Button, the gate must be armed. Use the arrow buttons to Select the Gate Openings. Edit to your own preferences. Gate is Armed.

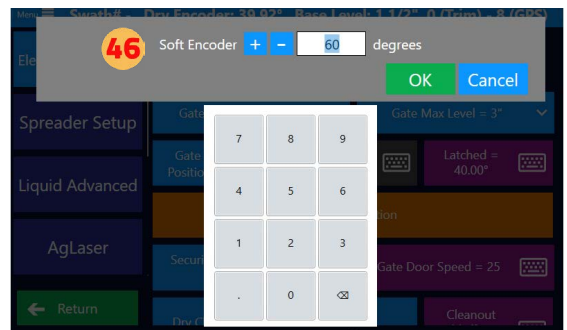
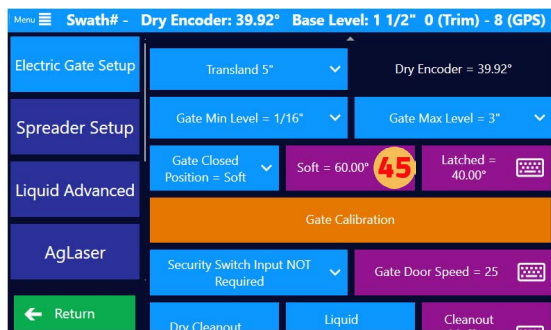

45 Tap 'Soft'

46 Set Soft Encoder

47 Tap 'Security Switch Input' button

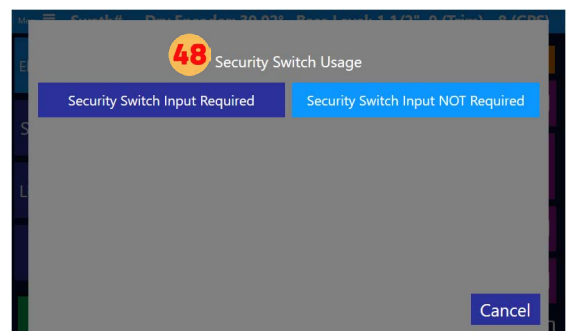
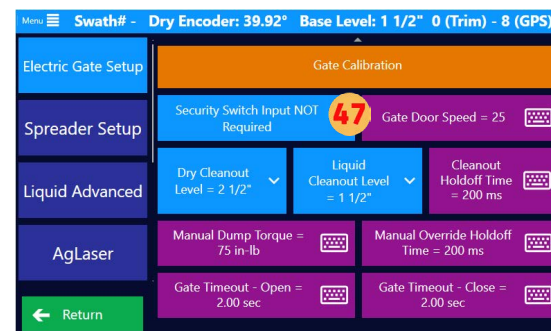

48 Choose Security Switch Usage

49 Tap 'Gate Door Speed'

50 Set Gate Door Speed. Then, click 'OK'.

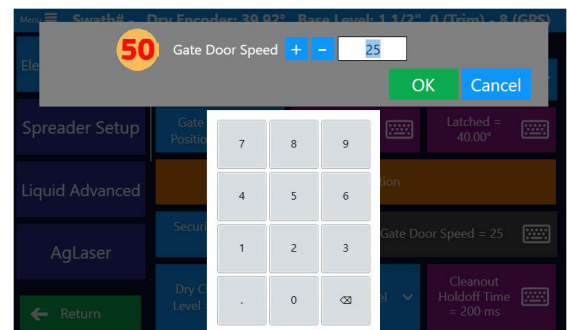
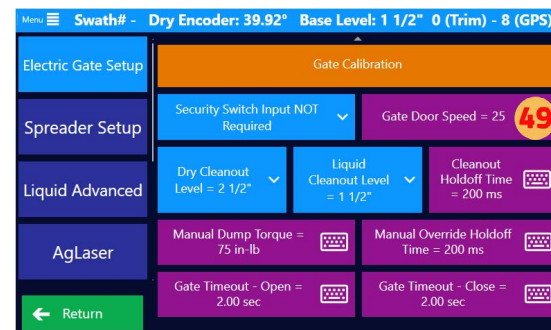

51 Tap 'Dry Cleanout Level'

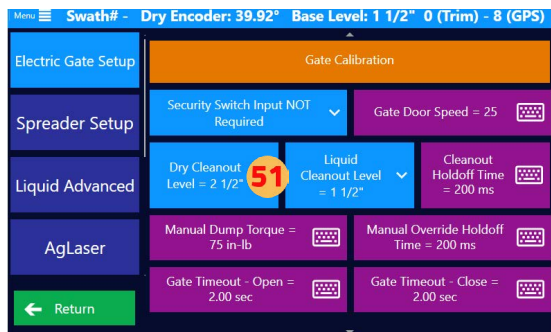

52 Set Dry Cleanout Level

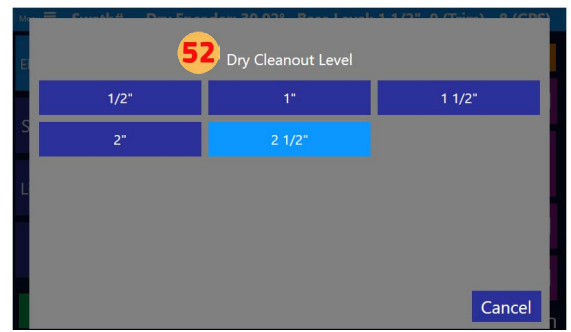

53 Tap 'Liquid Cleanout Level'

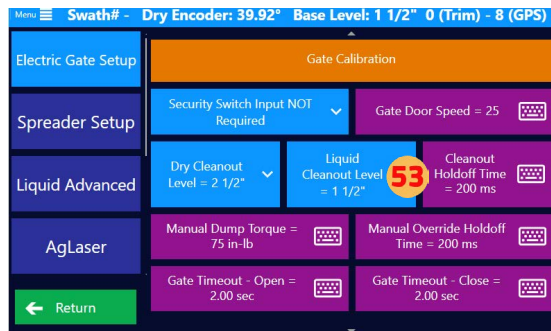

55 Tap 'Cleanout Holdoff Time'

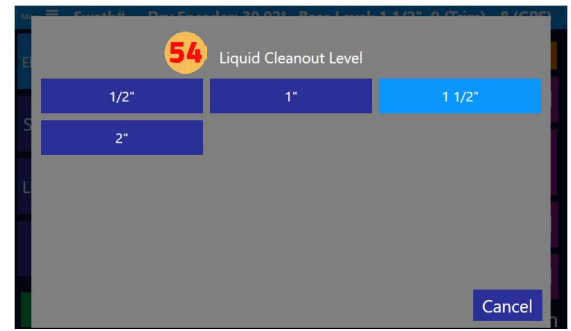

56 Set Cleanout Holdoff Time. Then, tap 'OK.'

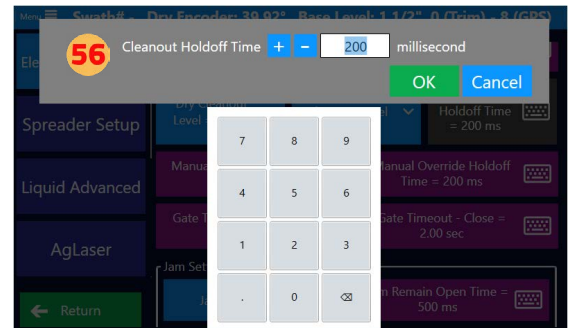
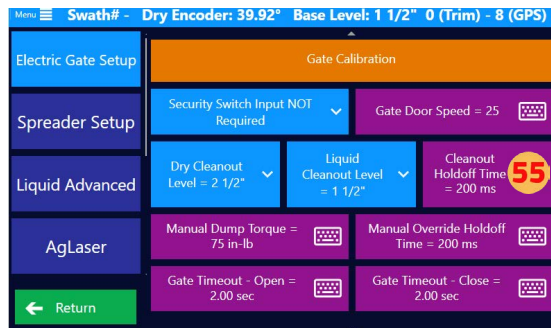

NOTE

The terms and definitions below will help explain some of the functions of the Transland Electric Gate. If you have questions during the next steps of the initial Transland Electric Gate setup, please refer to these terms and definitions.

Term	Definition
Manual Dump Torque	This is the threshold torque value that releases the electric actuator. The “Manual Dump Torque” is the result of the applied force to the jettison (emergency) handle inside the cockpit. This interacts with the electric motor and applies torque to the input shaft of the electric actuator. The range is 50 - 250 in-lb.
Manual Override Holdoff	When you apply the force through the jettison handle, this is a time period called the “Manual Override Holdoff.” The range is 50 to 2500 milliseconds. This prevents unintended jettison by requiring the manual dump torque to be applied consistently for this hold off time
Gate Timeout - Open	The time at which the gate will stop trying to open if the target value has not been reached. The gate timeout - open mode is not available as of November 2023.

Term	Definition
Gate Timeout - Close	The time at which the gate will stop trying to close if the target value has not been reached. The range is 1.0 to 2.5 seconds.
Jam Mode	There are two jam modes: 1) automatic and 2) manual.
Jam Remain Open Time	For auto mode: When the gate jams, it will open to a pre-determined level and for a pre-determined time. The range is 0.0 to 2.0 seconds.
Jam Open to Level	For auto mode: When the gate jams, it will open to a pre-determined level and for a pre-determined time. The range is 0.0” to 2.0”.
No Jam Deadband before Soft-Position	The “No Jam Deadband” is from the selected opening before soft level to the selected gate latched level.
Jammed Gate Torque	The “Jammed Gate Torque” is a pre-cautionary feature that releases the gate if the torque required to close reaches a preset torque value. The range is 200 to 530 in-lb.

55 Tap ‘Manual Dump Torque.’ Set Manual Dump Torque. Then, tap ‘OK.’

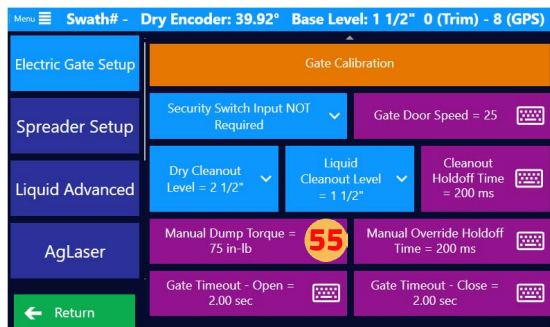

56 Tap ‘Manual Override Holdoff Time.’ Set Manual Override Holdoff Time. Then, tap ‘OK.’

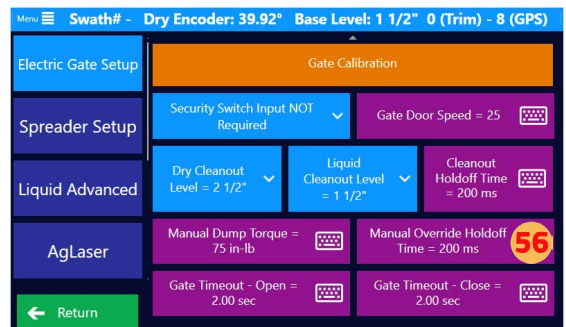

57 Tap ‘Gate Timeout - Open.’ Set Gate Timeout - Open. Then, tap ‘OK.’

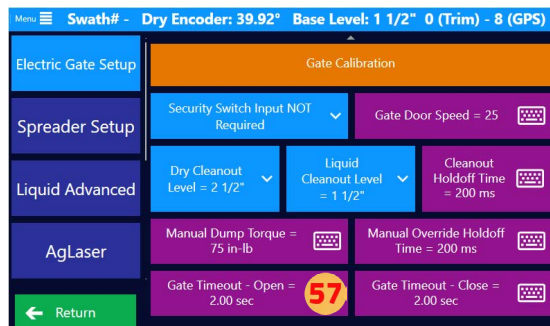

58 Tap ‘Gate Timeout - Close.’ Set Gate Timeout - Close. Then, tap ‘OK.’

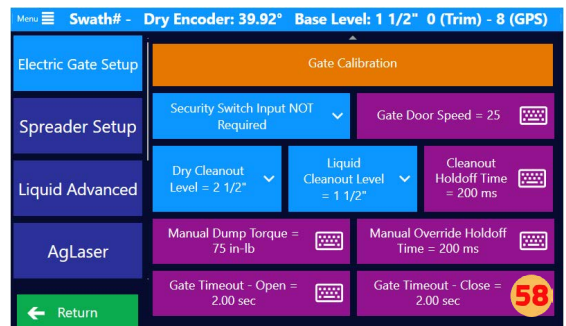

59 Select and Set all Jam Settings

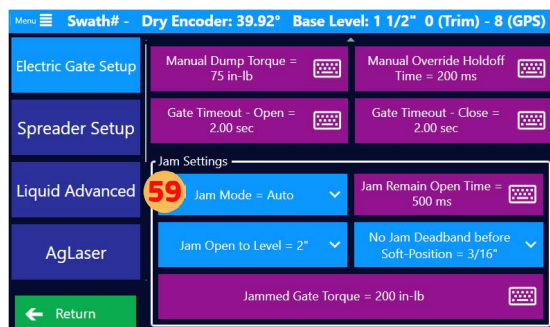

NOTE
Falcon must be turned on to use the clean-out switch.

4.3 LEVELS SETUP FOR ELECTRIC GATE

Key Differences in Levels vs. Single Profiles

- Standardization vs. Customization: Levels are more about standard, preset options, while single profiles offer more room for customization and fine-tuning.
- Ease of Use vs. Precision: Levels provide ease of use and quick selection, useful in general or less sensitive applications. Single profiles, on the other hand, offer greater precision, which is beneficial in more specialized or sensitive applications.
- Application Scope: Levels might be sufficient for general agricultural needs, while single profiles could be necessary for tasks requiring more precise control over material distribution, such as in areas near sensitive ecosystems or when applying high-value or highly potent materials. There are multiple single profiles built within the Falcon software that can be used or edited to a pilot's preferences.

- 1 Tap 'Application'
- 2 Tap 'Flow Control'
- 3 Tap 'Control Mode'
- 4 Tap 'Levels Only'
- 5 Tap 'Base Gate Level' and set it

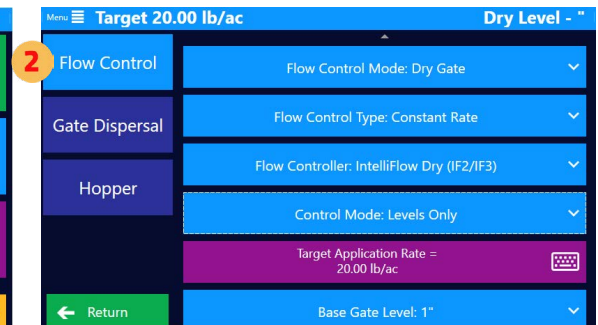

- 6 Select the 'Target Gate Opening'

Selecting the target gate level will automatically set a 'default every speed.'

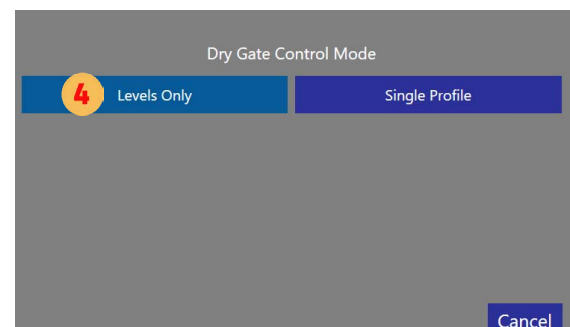
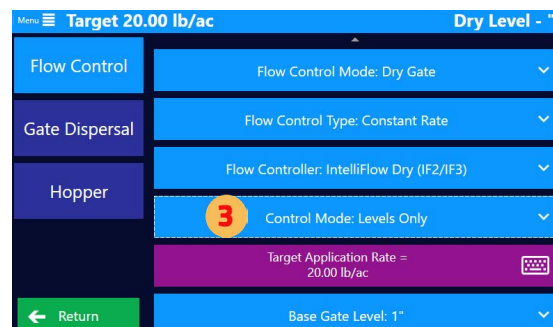

- 7 If you want to change the every Speed, Tap 'Every Speed' and set it

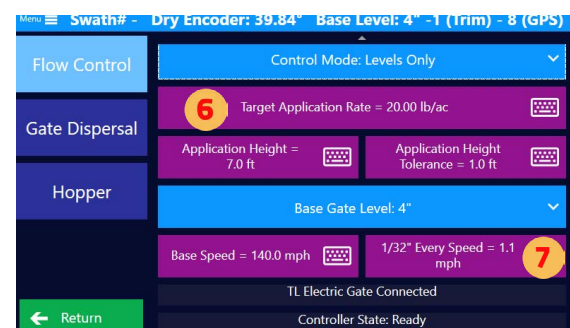
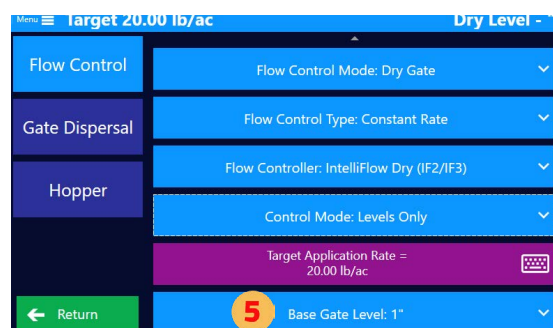

NOTE

Target Application Rate

The target application rate is the input to the hopper calculation for the remaining product.

Reset Dry Gate Area & Total Dry Gate Time

At the bottom of the dry gate flow control screen, a pilot can reset the total dry gate area and the total dry gate time.



TIP

If Ag Laser and Wind Offset are turned on in your aircraft, you can set 'Application Height' and 'Application Height Tolerance.'

4.4 SINGLE PROFILE SETUP FOR ELECTRIC GATE

Key Differences in Levels vs. Single Profiles

- Standardization vs. Customization: Levels are more about standard, preset options, while single profiles offer more room for customization and fine-tuning.
- Ease of Use vs. Precision: Levels provide ease of use and quick selection, useful in general or less sensitive applications. Single profiles, on the other hand, offer greater precision, which is beneficial in more specialized or sensitive applications.
- Application Scope: Levels might be sufficient for general agricultural needs, while single profiles could be necessary for tasks requiring more precise control over material distribution, such as in areas near sensitive ecosystems or when applying high-value or highly potent materials. There are multiple single profiles built within the Falcon software that can be used or edited to a pilot's preferences.

- 1 Tap 'Application'
- 2 Tap 'Flow Control'
- 3 Tap 'Control Mode'
- 4 Tap 'Single Profile'
- 5 If you want to alter the product that is selected for the single profile in any way, tap 'Single Profile Settings.'



You will need to copy a default dry profile into an editable profile.

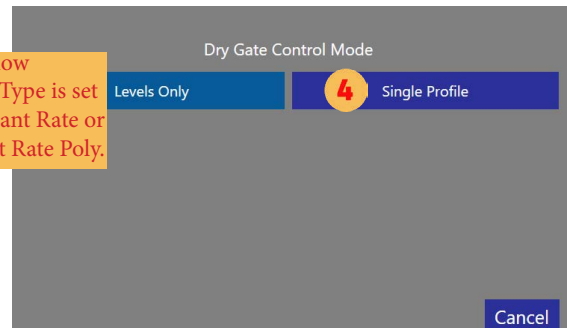
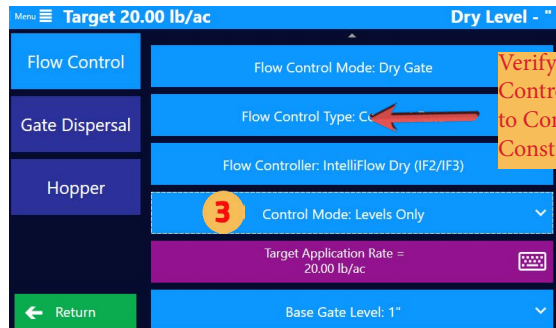

- 6 Tap 'Edit Profiles'
- 7 Tap 'Copy'
- 8 Name the Dry Product Profile and tap 'OK.'

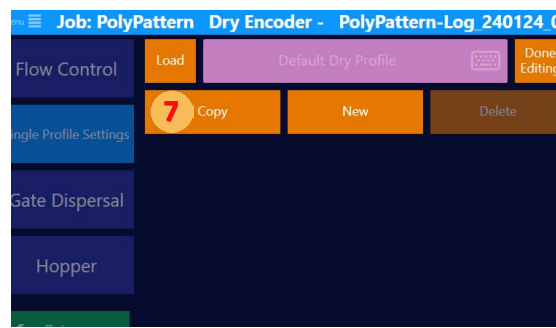
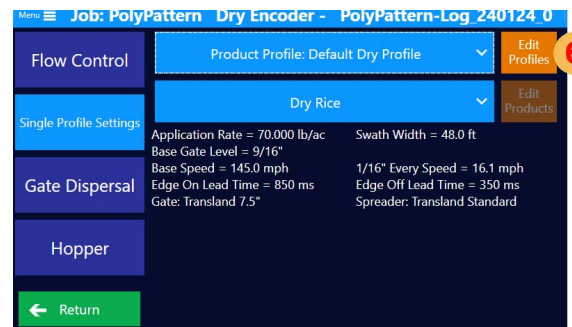
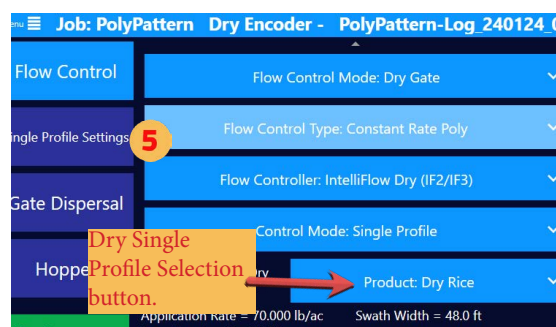

- 9 Tap 'Done Editing'
- 10 Tap 'Edit Products'
- 11 Load the Product you want
- 12 Edit the various settings per usage preferences

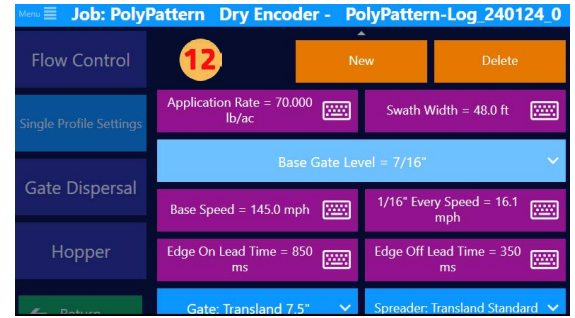
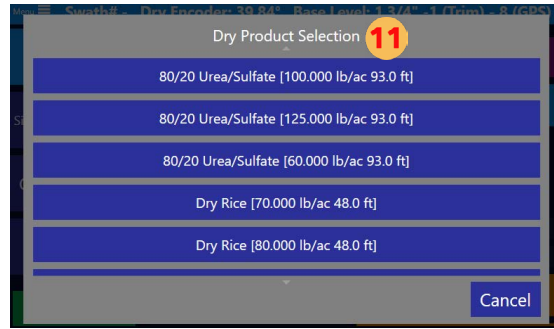
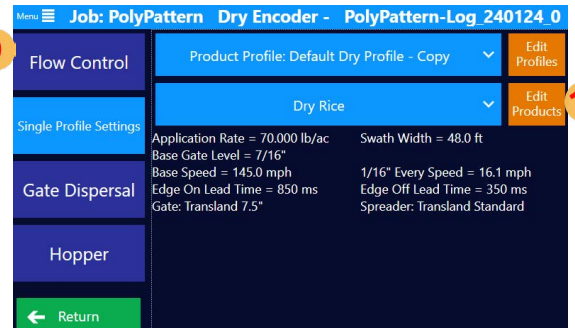
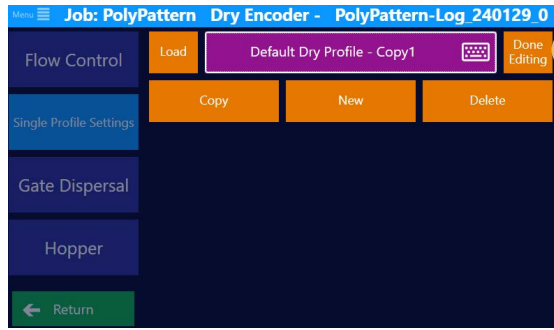

4.5 HYDRAULIC GATE BOX INITIAL SETUP

Selecting Flow Control Mode

Note: This section only applies to Falcon Pro systems.

- 1 Tap 'Advanced'
- 2 Tap 'Visibility'
- 3 Tap 'Falcon Features'
- 4 Click the box for 'Control Mode: Dry Gate'
- 5 Go to Main Menu and tap 'Applications'
- 6 Tap 'Flow Control Mode'
- 7 Tap 'Dry Gate'
- 8 Tap 'Flow Control Type'
- 9 Tap 'Constant Rate'
- 10 Tap 'Flow Controller'
- 11 Tap 'IntelliFlow Dry (IF2/IF3)'

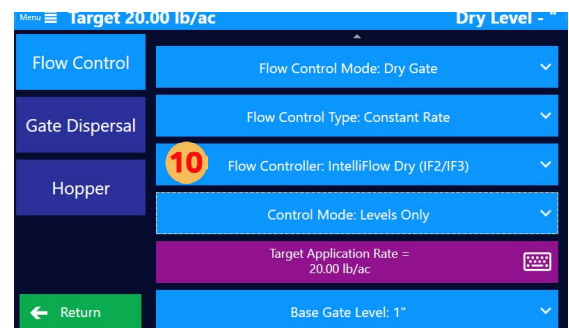
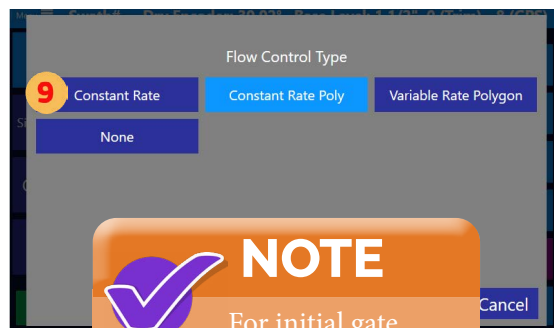
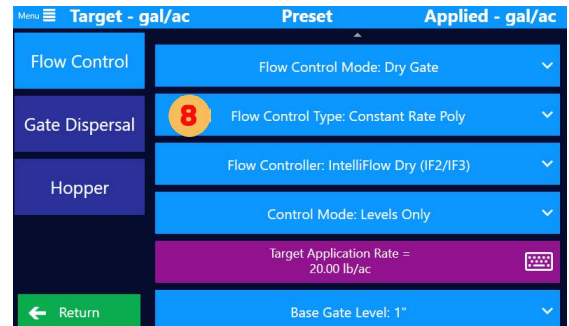
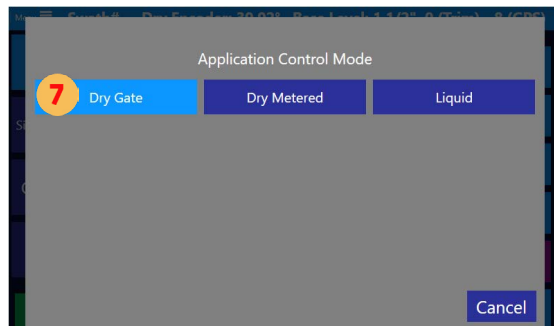
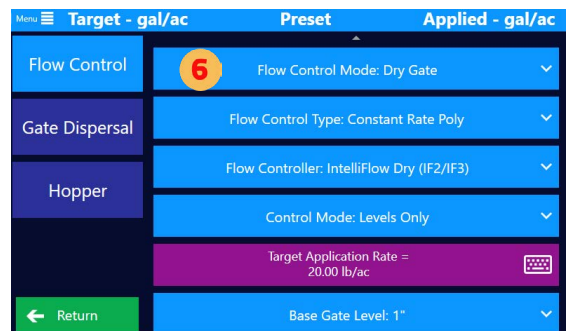
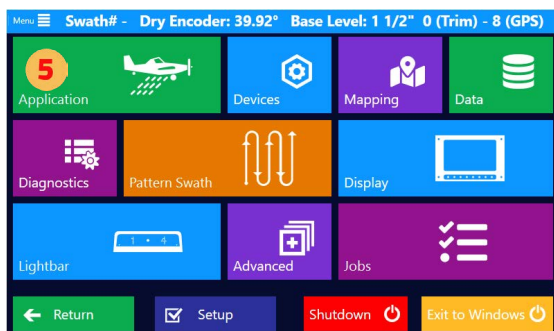

NOTE
 For initial gate setup, select "Constant Rate." If your jobs contain polys, after initial setup please change to "Constant Rate Poly."

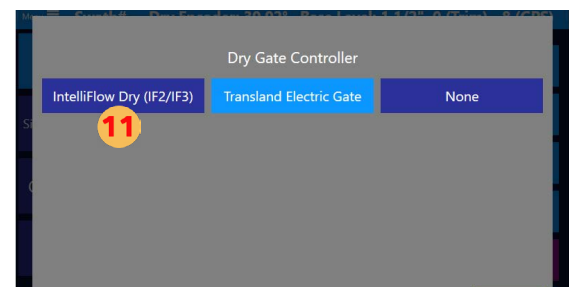

Calibration

Note: This section requires two people.

12 Go to Main Menu and tap 'Devices'

13 Tap 'Gate Setup'

14 Tap 'Latched Encoder'

15 With the gate latched/locked closed, adjust encoder on the gate until the encoder range for the min value is 130-145. If value is not in that range, adjust position sensor to be within that range. The encoder value is adjusted by loosening the screws on the position sensor and rotating it until it is in the min value range.

16 Set Latched Encoder number to match actual encoder value. Then, tap 'OK.'

17 Tap 'Gate Calibration'

18 Tap 'Change'

19 Tap 'Gate Actuation Time'

20 Set gate actuation time. Then, tap 'OK.'

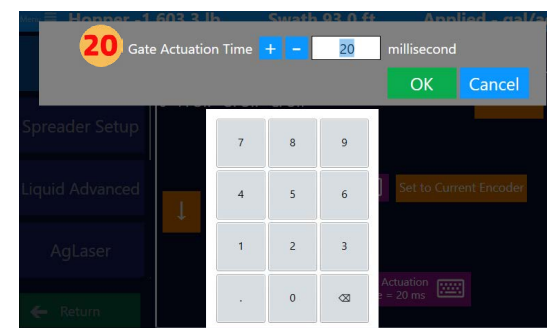
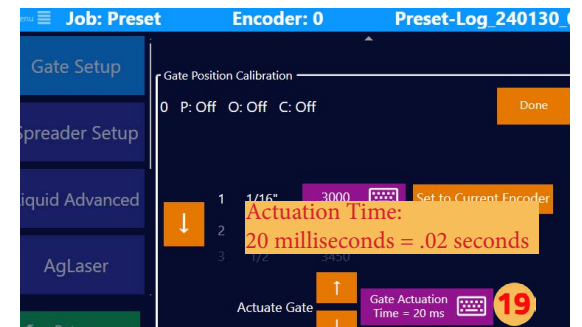
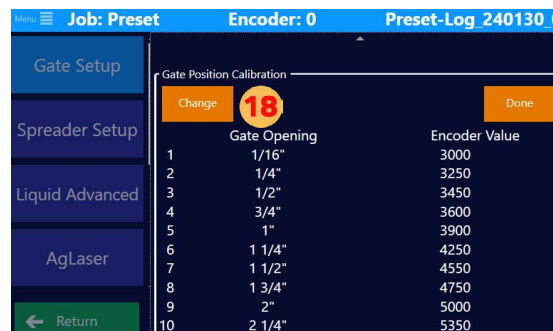
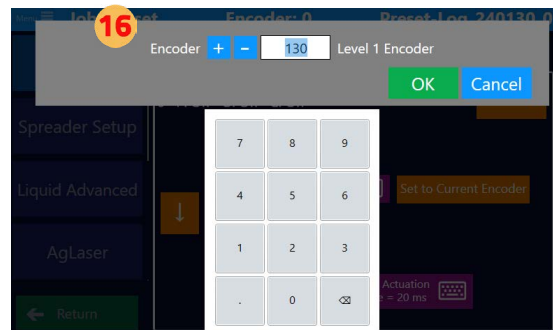
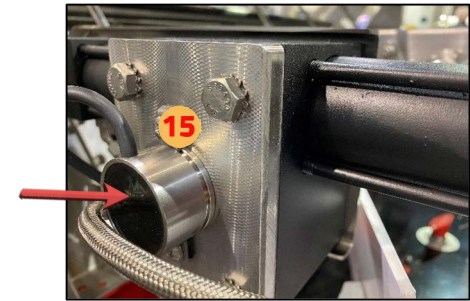

NOTE

The "Gate Actuation Time" button can decrease or increase the amount of time sending the command to the pump. Adjusting the time will allow less or more time to get the correct position.

21 In the cockpit, flip on the arm and pump switches.

22 Tap the actuate arrows to actuate the gate box.

23 Set the gate box to match the current openings. To apply, tap 'Set to Current Encoder.'

Tap side arrows to change openings or tap the encoder value button to make changes.
Note: Repeat for each opening.

24 Tap 'Done' when each position is set.

25 Tap 'Done'

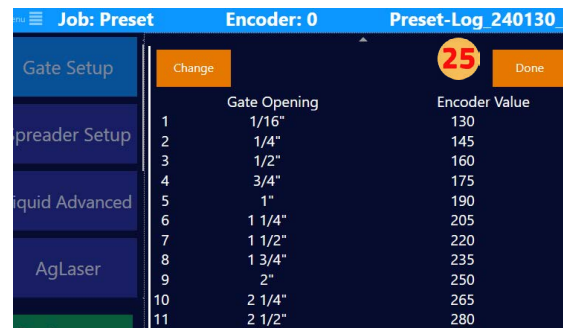
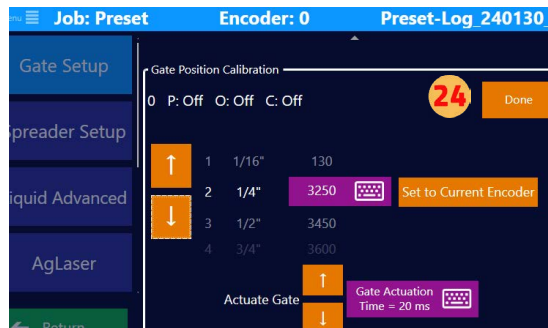
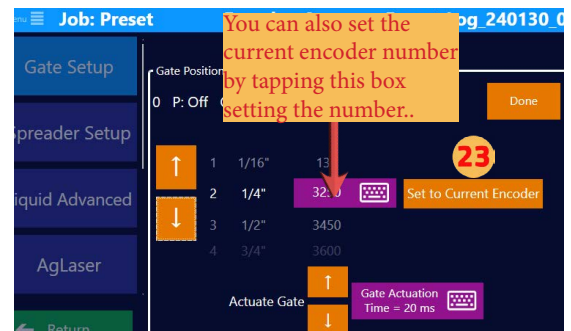
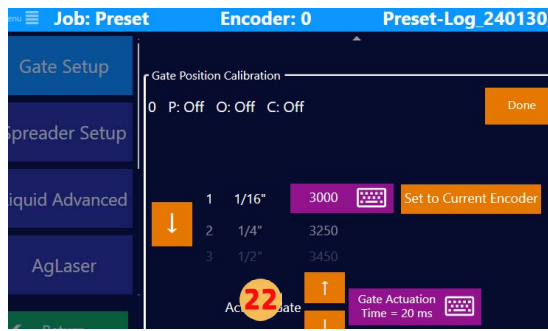

NOTE

It is optional to disconnect hydraulics and then manually adjust the gate. There is a hydraulic disconnect in the cockpit, which is usually a red knob.

Auto Tuning



NOTE

There are two ways to tune hydraulic gate: Auto Tuning and Manual Tuning.



WARNING

Gate will move automatically and without warning during this process. All people need to stay clear of the gate during this process.

26 Tap 'Gate Tuning'

27 Tap 'Auto Tune'

28 In the cockpit, flip on the arm and pump switches.

29 Tap 'Start'

This will take a few minutes. When a bar is complete, it will turn completely blue.

30 Tap 'Done'

31 Unarm Gate

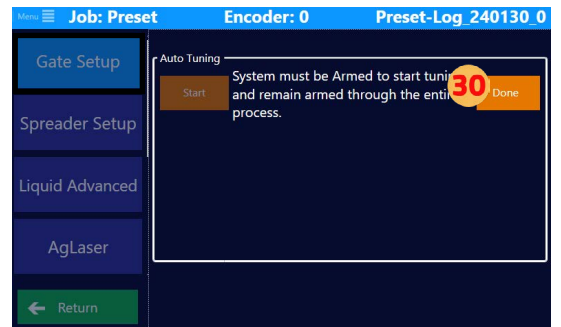
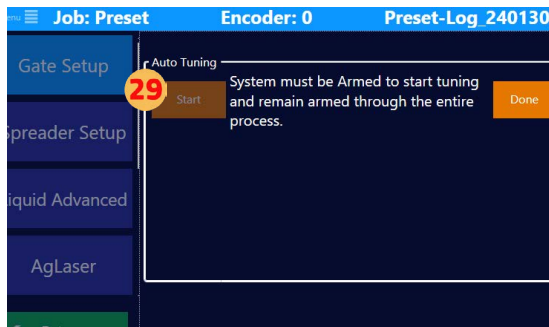
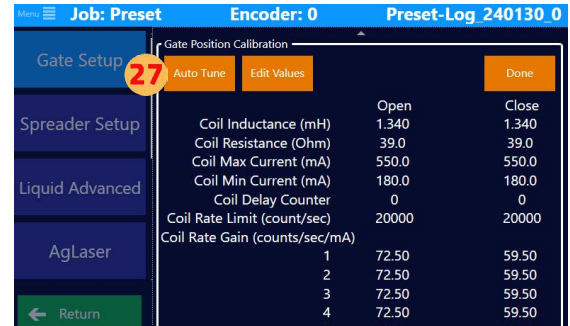
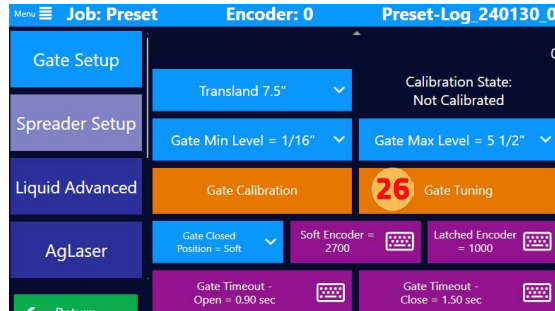

Manual Tuning

32 Tap 'Gate Tuning'

33 Tap 'Edit Values'

34 Manually set coil values by tapping a value and then editing it.

35 Input value. Then, tap 'OK.'

Note: Repeat Steps 35 and 36 for every value you want to set.

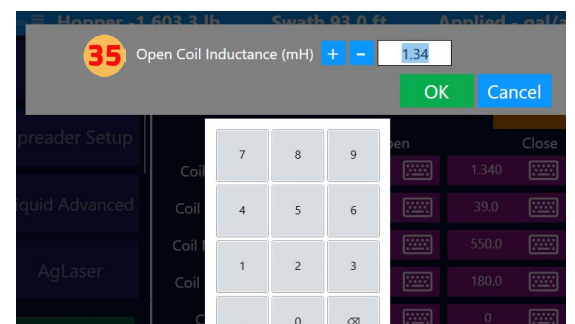
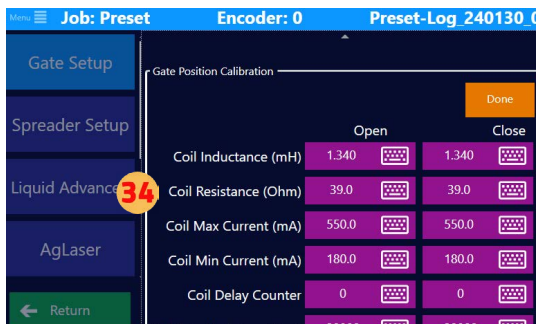
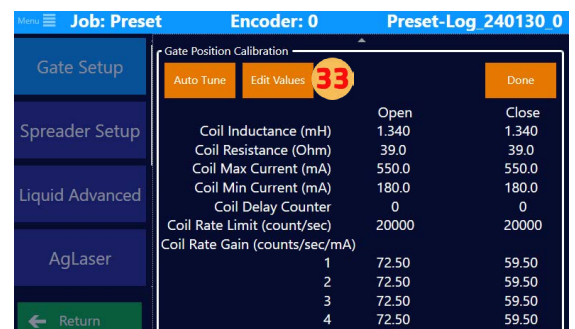
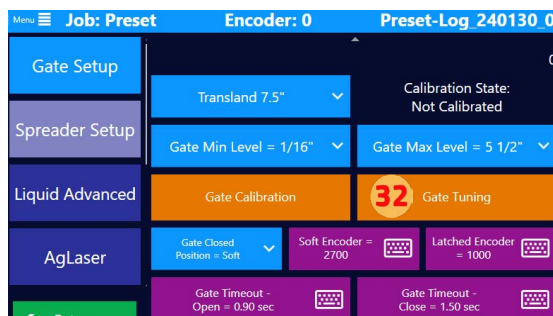

- 36** Tap 'Done' when all values are set
- 37** Tap 'Done'

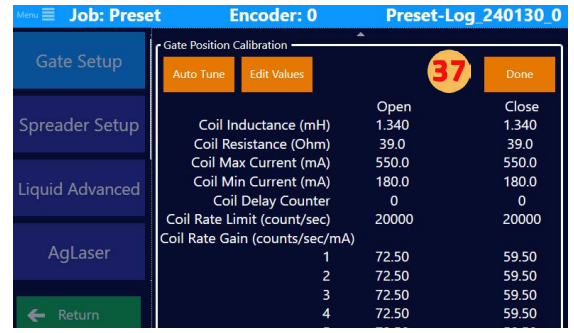
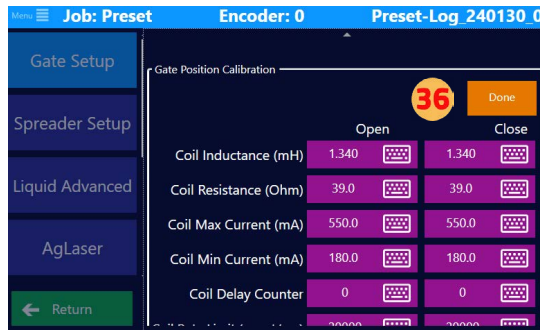

4.6 LEVELS SETUP FOR HYDRAULIC GATE

Key Differences in Levels vs. Single Profiles

- Standardization vs. Customization: Levels are more about standard, preset options, while single profiles offer more room for customization and fine-tuning.
- Ease of Use vs. Precision: Levels provide ease of use and quick selection, useful in general or less sensitive applications. Single profiles, on the other hand, offer greater precision, which is beneficial in more specialized or sensitive applications.
- Application Scope: Levels might be sufficient for general agricultural needs, while single profiles could be necessary for tasks requiring more precise control over material distribution, such as in areas near sensitive ecosystems or when applying high-value or highly potent materials. There are multiple single profiles built within the Falcon software that can be used or edited to a pilot's preferences.

- 1 Tap 'Application'
- 2 Tap 'Flow Control'
- 3 Tap 'Control Mode'
- 4 Tap 'Levels Only'
- 5 Tap 'Base Gate Level' and set it

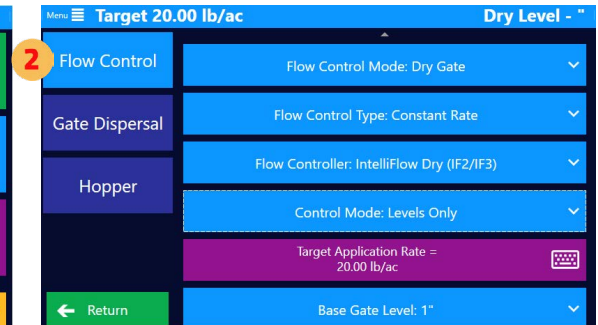

- 6 Select the 'Target Gate Opening'

Selecting the target gate level will automatically set a 'default every speed.'

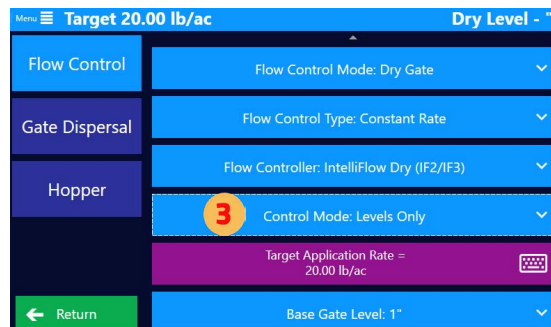

- 7 If you want to change the every Speed, Tap 'Every Speed' and set it

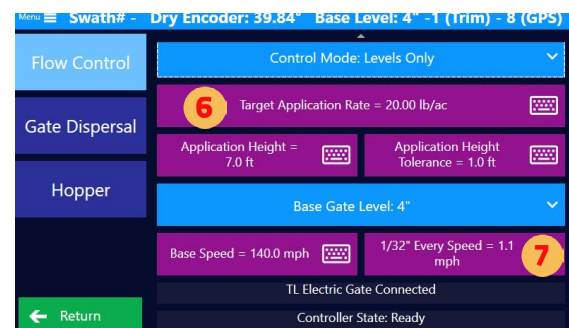
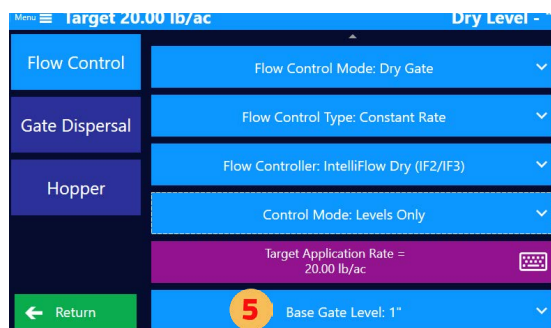

NOTE

Target Application Rate

The target application rate is the input to the hopper calculation for the remaining product.

Reset Dry Gate Area & Total Dry Gate Time

At the bottom of the dry gate flow control screen, a pilot can reset the total dry gate area and the total dry gate time.



TIP

If Ag Laser and Wind Offset are turned on in your aircraft, you can set 'Application Height' and 'Application Height Tolerance.'

4.7 SINGLE PROFILE SETUP FOR HYDRAULIC GATE

Key Differences in Levels vs. Single Profiles

- Standardization vs. Customization: Levels are more about standard, preset options, while single profiles offer more room for customization and fine-tuning.
- Ease of Use vs. Precision: Levels provide ease of use and quick selection, useful in general or less sensitive applications. Single profiles, on the other hand, offer greater precision, which is beneficial in more specialized or sensitive applications.
- Application Scope: Levels might be sufficient for general agricultural needs, while single profiles could be necessary for tasks requiring more precise control over material distribution, such as in areas near sensitive ecosystems or when applying high-value or highly potent materials. There are multiple single profiles built within the Falcon software that can be used or edited to a pilot's preferences.

- 1 Tap 'Application'
- 2 Tap 'Flow Control'
- 3 Tap 'Control Mode'
- 4 Tap 'Single Profile'
- 5 If you want to alter the product that is selected for the single profile in any way, tap 'Single Profile Settings.'

You will need to copy a default dry profile into an editable profile.

- 6 Tap 'Edit Profiles'
- 7 Tap 'Copy'
- 8 Name the Dry Product Profile and tap 'OK.'

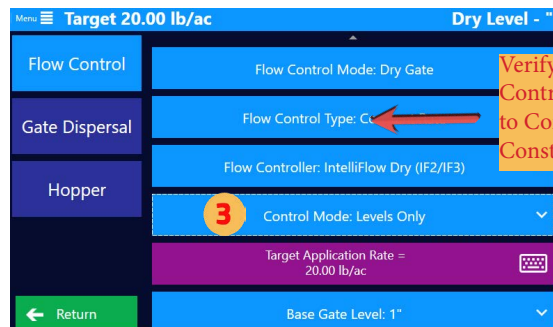
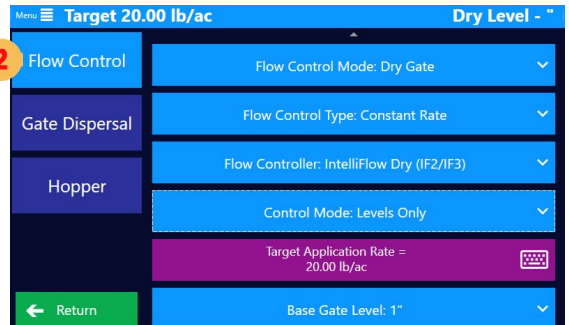

Verify Flow Control Type is set to Constant Rate or Constant Rate Poly.

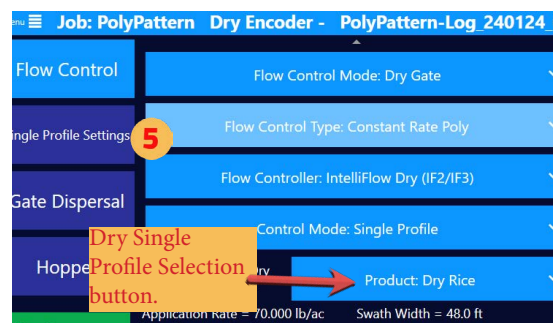
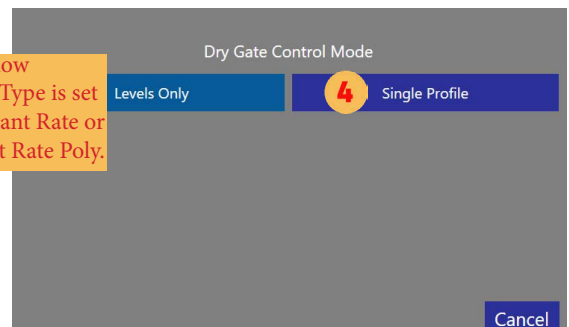

Dry Single Profile Selection button.

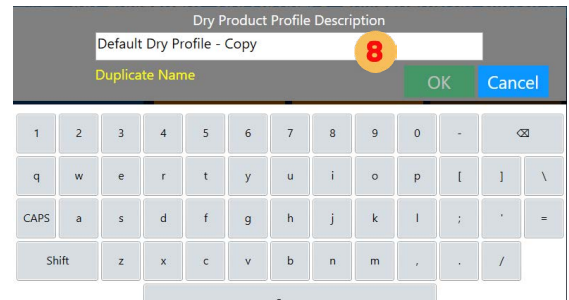
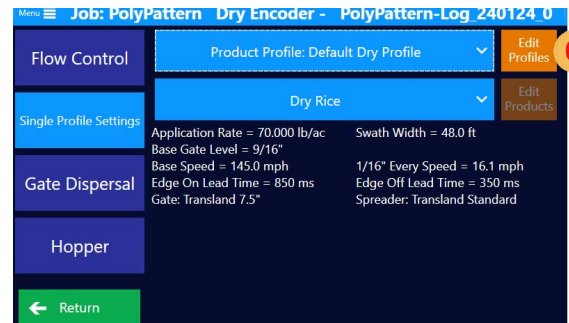

- 9 Tap 'Done Editing'
- 10 Tap 'Edit Products'
- 11 Load the Product you want
- 12 Edit the various settings per usage preferences

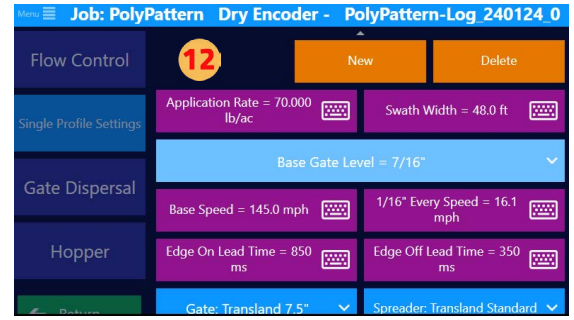
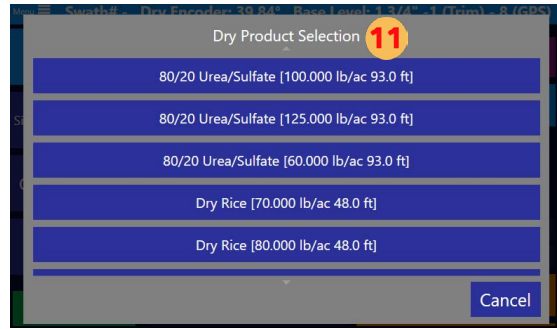
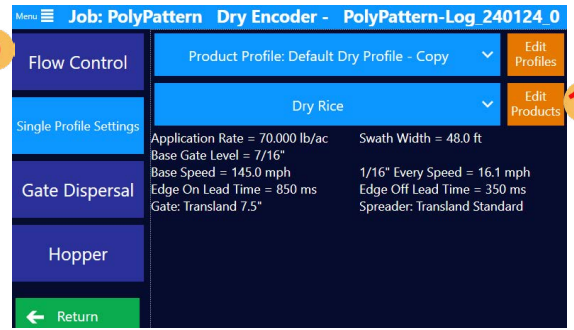
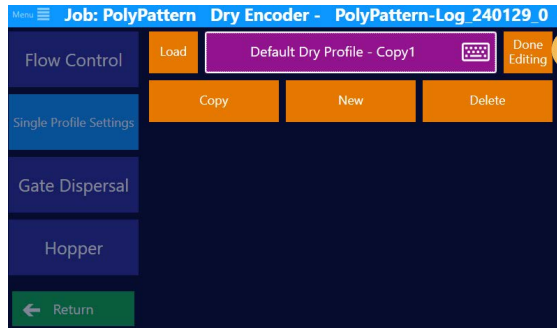

APPENDIX A: FALCON & FALCON PRO SIMULATOR

Minimum system requirement for installing the Satloc Falcon & Falcon Pro Simulator:

- Windows 8 OS and above
- 2 G RAM memory
- 32 G Hard drive

How-To Download the Satloc Falcon & Falcon Pro Simulator:

- Visit the Resources page on Satloc’s website - <https://satloc.com/resources/>
- Scroll down to the Falcon & Falcon Pro Simulator area
- When you click the “Click Here to Download the Simulator,” the files will automatically download onto your computer.
- Open the zipped file and follow your computer prompts.

Troubleshooting the Install for the Satloc Falcon & Falcon Pro Simulator:

There are a couple of scenarios that might cause installation difficulties. So, here are some troubleshooting steps.

1. Downloaded zip file needed to be unlocked prior to unzipping and installing.
 - a. Once the zip file is downloaded. Right-click on the file and select “Properties.”
 - b. On the properties screen, uncheck the “Unblock” check box before extracting and installing.

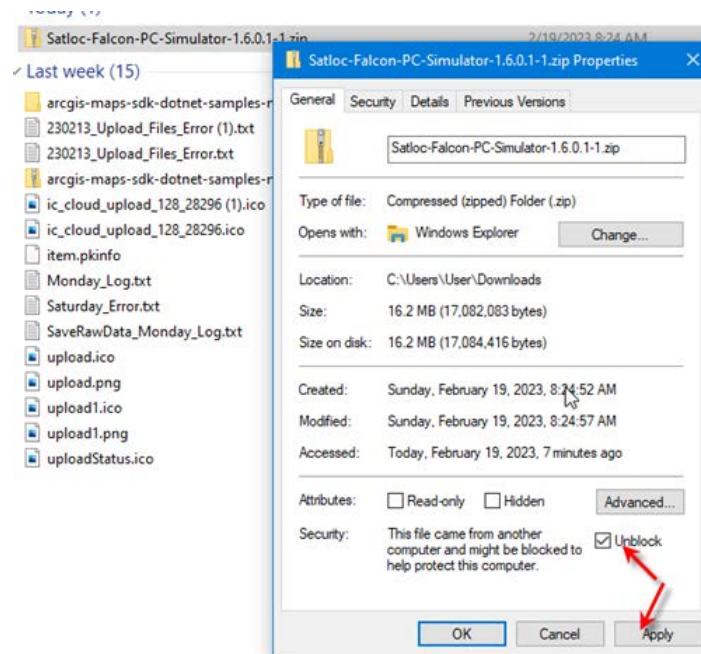

2. The user’s computer might be locked down to prevent downloading and installing software.
 - a. Suppose you work for a company that prevents you from automatically downloading and installing software. In that case, you must contact your company’s Admin for privileges to download and install the software.

Path to GPS Signal in the Simulator:

- Main Menu > Mapping > Map Setup > GPS Input > Internal Simulator
- Tap ‘Return’ button twice to go to Moving Map Screen

APPENDIX B: MOVING MAP SCREEN TOP & LEFT DISPLAY OPTIONS

Table B-1: Display Settings/Functions Options under Application Tab

Application	Flow Control	Job/Polygon	Tracking	Other
Setting/Function	Definition			
Angle of Intercept	Displays angle off to straighten towards destination			
Cross Track	Displays distance off to line up with destination			
Current Hopper Dry	Button (popup) to set current hopper load for dry material			
Current Hopper Liquid	Button (popup) to set current hopper load for liquid material			
Double Spray	Tells when course center line intercepts with center line of already sprayed area (<i>option also in Flow Control menu</i>)			
Pattern (Only Available in Left Display)				
Poly Pattern (Only Available in Left Display)				
Quick Track X Total Swaths (Only Available in Left Display)				
Swath # (Absolute)	This is the swath number from 1 to X without any regard for repeated patterns or pre-pattern back-to-back.			
Swath # (Relative)	This is the current swath number within a particular pattern. For example, if a 20-pass Racetrack is repeating, this number would count from 1 to 20 and then start again with 1-20.			
Swath Width	Button (popup) to set current swath width			

Table B-2: Display Settings/Functions Options under Flow Control Tab

Application	Flow Control	Job/Polygon	Tracking	Other
Setting/Function	Definition			
Application Rate Liquid	When applying, the Application Rate will show. When not applying the Pattern Area will show. This is a convenient setting to have two sets of data in one location.			
Boom Pressure				
Double Spray	Tells when course center line intercepts with center line of already sprayed area (<i>option also in Application menu</i>)			
Dry Gate Base Speed	Displays set base speed for dry gate			
Dry Gate Every Speed	Displays amount of increase to base level per step up increase of speed			
Dry Gate Target Level				
Flow Control	Button shortcut to Application > Flow Control			
Flow Rate Liquid	Displays current liquid flow rate (gal/min)			
Flowmeter Cal Factor (Only Available in Left Display)				
Flowmeter Standard Deviation				
Gate Encoder				
Gate Level				
Pattern Area/Application Rate Liquid				
Target Application Rate - Dry	Displays desired application rate for dry products (amount per area, gal/ac)			
Target Application Rate - Liquid	Displays desired application rate for liquid products (amount per area, gal/ac)			
Valve Encoder	Displays position information from valve encoder			

Table B-3: Display Settings/Functions Options under Job/Polygon Tab

Application		Flow Control	Job/Polygon	Tracking	Other
Setting/Function		Definition			
Daily Area					
Daily Liquid Volume					
Daily Time					
Job Area					
Job Liquid Volume					
Job Time					
Pattern (Only Available in Top Display)					
Pattern Area					
Pattern Liquid Volume					
Pattern Time					
Total Area		Shows total area applied			
Total Liquid Volume					
Total Time					

Table B-4: Display Settings/Functions Options under Tracking Tab

Application		Flow Control	Job/Polygon	Tracking	Other
Setting/Function		Definition			
GPS Altitude		Shows current GPS altitude			
GPS Bearing		Shows current GPS bearing			
GPS Ground Speed		Shows current travel speed			
GPS Satellite Count		Shows number of connected satellites			
GPS Status		Shows connection status to GPS (i.e. 'Good')			
Guidance Distance					
Guidance Heading					
Guidance Time					

Table B-5: Display Settings/Functions Options under Other Tab

Application		Flow Control	Job/Polygon	Tracking	Other
Setting/Function		Definition			
Current Job					
Current Log					
Date/Time (Only Available in Left Display)		Shows current date and time - only displays in left display area			
Guidance Mode (Only Available in Left Display)					
Blank					

APPENDIX C: HOTKEY OPTIONS

Table C-1: Application Display Settings/Functions

Setting/Function	Definition
Angle of Intercept	Displays angle off to straighten towards destination
Cross Track	Displays distance off to line up with destination
Current Hopper Liquid	Button (popup) to set current hopper load
Double Spray	Tells when course center line intercepts with center line of already sprayed area (<i>option also in Flow Control menu</i>)
Swath # (Absolute)	This is the swath number from 1 to X without any regard for repeated patterns or pre-pattern back-to-back.
Swath # (Relative)	This is the current swath number within a particular pattern. For example, if a 20-pass Racetrack is repeating, this number would count from 1 to 20 and then start again with 1-20.
Swath Width	Button (popup) to set current swath width

Table C-2: Flow Control Display Settings/Functions

Setting/Function	Definition
Application Rate Liquid	When applying, the Application Rate will show. When not applying the Pattern Area will show. This is a convenient setting to have two sets of data in one location.
Double Spray	Tells when course center line intercepts with center line of already sprayed area (<i>option also in Application menu</i>)
Dry Gate Base Level	Displays set base level for dry gate
Dry Gate Base Speed	Displays set base speed for dry gate
Dry Gate Every Speed	Displays amount of increase to base level per step up increase of speed
Flow Control	Button shortcut to Application > Flow Control
Flow Rate Liquid	Displays current liquid flow rate (gal/min)
Gate Encoder	
Target Application Rate - Dry	Displays desired application rate for dry products (amount per area, gal/ac)
Target Application Rate - Liquid	Displays desired application rate for liquid products (amount per area, gal/ac)
Total Area/Application Rate - Liquid	Displays desired application rate (amount per area, gal/ac)
Valve Encoder	Displays position information from valve encoder

Table C-3: Job/Polygon Display Settings/Functions

Setting/Function	Definition
Distance to Waypoint	Shows distance away from currently loaded waypoint (<i>option also in Tracking menu</i>)
Distance to Poly	Shows distance away from currently loaded polygon (<i>option also in Tracking menu</i>)
Heading to Waypoint	Shows heading to currently loaded waypoint (<i>option also in Tracking menu</i>)
Heading to Poly	Shows heading to currently loaded polygon (<i>option also in Tracking menu</i>)
Pattern	Button (popup) to set swath pattern
Time to Waypoint	Shows amount of time to currently loaded waypoint (<i>option also in Tracking menu</i>)
Time to Poly	Shows amount of time to currently loaded polygon (<i>option also in Tracking menu</i>)
Total Area	Shows total area applied

SATLOC[®]

Technical Support

To find an authorized dealer near you, visit www.satloc.com.

Satloc

support@satloc.com

Call or Text 833-4-Satloc

(833) 472-8562

www.satloc.com

1206 Hatton Rd.

Wichita Falls, TX 76302

THE NEXT GENERATION OF GUIDANCE IS HERE!

SATLOC.COM